











EN

OPERATING MANUAL

alfea A.I. R32

Air/water heat pump split 1 service

Contents

 Safety instructions	3
 Overview of installation	4
Precautions and warnings about your installation	4
Appliance end-of-life	5
 Carrying out the installation	6
User Interface	6
Display Description	7
Navigating the Menus	8
Modifying Settings	8
Menu Structure	9
 Manual mode	10
 Absence	12
 Active functions	13
 Temperature setting	13
 Programming	14
 Energy consumption	15
 Settings	15
 Maintenance	18
Regular checks	18
Checking the outdoor unit	18
Checking the refrigeration circuit	18
Error messages	19

 This document was written in French and translated.

► Symbols and definitions



Warning. Risk of serious injury to the person and / or risk of damage to the machine. Observe the warning.



Important information that must always be kept in mind.



Tips and tricks / Advice



Bad practice



Warning : Electricity hazard.



Warning : Slightly flammable refrigerant.



Safety instructions

Please comply with the following instructions in order to avoid any risk of injury or inappropriate use of the appliance.

Commissioning

Do not switch the appliance ON until every filling operation has been performed

Do not attempt to install this appliance yourself. This heat pump must be installed by qualified personnel holding a certificate of competence.

The installation must always be properly earthed and fitted with a safety circuit breaker.

Do not change the power supply.

The appliances are not fireproof and therefore **MUST NOT** be installed in an explosive environment.

How to Use

This appliance can be used by children from 8 years old and by persons with reduced physical, sensory or mental capabilities or without experience or knowledge, provided that they are properly supervised or if they have been given instructions on how to use the appliance safely and the risks involved have been understood. Children must not play with the appliance. Cleaning and maintenance by the user must not be carried out by children without supervision.

This device is not intended for use by persons (including children) whose physical, sensory or mental capabilities are reduced, or persons without experience or knowledge, unless they have benefited from the intermediary of a person responsible for their safety, surveillance or prior instructions concerning the use of the device. Children should be supervised to ensure that they do not play with the appliance.

Do not let children insert foreign objects into the propeller protection grate or climb on the outdoor unit. The fins of the air heat exchanger are extremely thin and can cause cuts.

Nothing should obstruct the air circulation through the evaporator and out from the fan.

The outdoor unit must only be installed outside. If a shelter is required, it must have broad openings on all 4 sides and respect the installation clearances (see your installation engineer).

Do not climb on the outdoor unit.

Caution: copper pipes that carry refrigerating fluid may be hot and cause burns.

The room in which the unit is operating must be correctly ventilated in order to avoid any shortage of oxygen in the event of a refrigerant gas leak.

If your installation location already meets safety standards, do not carry out any modifications (ventilation, exhaust evacuation, openings, etc.) without the advice of your installation engineer.

Do not place any heat source under the remote control.

To avoid the risk of suffocation, keep plastic bags or plastic film of packaging materials away from young children.

Maintenance

Do not try to repair the appliance yourself.

If the power cable is damaged, it must be replaced by qualified personnel to avoid a danger.

This appliance does not contain any components which can be repaired by the user. Removing either of the covers can expose you to dangerous electrical voltages.

Switching off the current is not sufficient to protect you from any external electrical shocks (condensers).

Do not open the outdoor unit or the hydraulic unit while they are in operation.

If you hear unusual noises, smell smoke or other odours coming from the appliance, turn off the power and contact your installation engineer.

Before starting any cleaning, turn off the power to the appliance.

Do not use aggressive cleaning liquids or solvents to clean the body work.

Do not use a pressure hose to clean the outdoor unit. You risk damaging the air exchanger and causing water ingress in the electrical circuits.



► Outdoor unit

The outdoor unit, as its name suggests, is placed outside your dwelling, and extracts energy from the outside air.

This unit was installed by your installer in a location where it is able to operate with best performance.

Nothing should obstruct the air circulation through the evaporator and out from the fan.

The water contained in the air may condense and flow out of the outdoor unit. The outdoor unit can generate a large volume of water called condensate.

In cold weather, this water freezes on contact with the exchanger and must be regularly removed using the defrosting cycles. The defrosting cycle is managed automatically by the control system and can produce steam emissions which are completely normal.

► Hydraulic unit

The hydraulic unit is located in your boiler room, cellar, garage, and transfers energy to the heating and domestic hot water circuits*.

The hydraulic unit contains the appliance's control system which manages the room temperature and the production of domestic hot water.

The hydraulic unit is fitted with an electrical backup* or boiler connection* which intervenes to provide additional heat during the coldest periods.

► Settings

Your installer has carefully adjusted your installation. Do not change the settings without their consent. If in doubt, do not hesitate to contact them.

Your heating system is controlled by adjustment in relation to the outdoor temperature (temperature control).

The outside sensor monitors the outdoor temperature.

The installation of a room thermostat (option) makes it possible to improve the operation of the control system (influence of the ambient temperature is taken into account).

► Radiators

In order to ensure operation of the control system, the room containing the thermostat must not also contain a thermostatic valve. If this is the case, it must be opened as far as possible.

► Underfloor heating system

A new underfloor heating system must initially be heated slowly to avoid any problems involving cracking. Check with your installer that this initial heating procedure has indeed been performed before freely using your heating system.

An underfloor heating system's significant inertia prevents sudden room temperature differences. However, this inertia implies a reaction time of around several hours (approx 6 hours).

Any changes to the setting must be made slowly and leave the installation sufficient time to react. Any exaggerated or abrupt adjustments to the settings always result in significant temperature fluctuations during the day.

Similarly if your dwelling has an underfloor heating system, do not reduce it or switch it off if you will be absent for only short periods. The reheating period is always quite long (approx 6 hours).

► Fan coils / dynamic radiators with an integrated control system

Do not use a room sensor in the area in question.

► Domestic Hot Water (DHW)*

When hot water is required, the heat pump adapts its priority to meet the request.

No heating is produced during the preparation of domestic hot water.

The heat pump produces the domestic hot water (DHW), which is then additionally heated, if required, by the electrical backup.

To ensure a DHW setpoint over 45°C, the electrical backup heating or boiler (boiler connection kit)* must be left on.

The electrical backup allows the correct operation of the anti-legionella cycles.

* depending on configuration / option

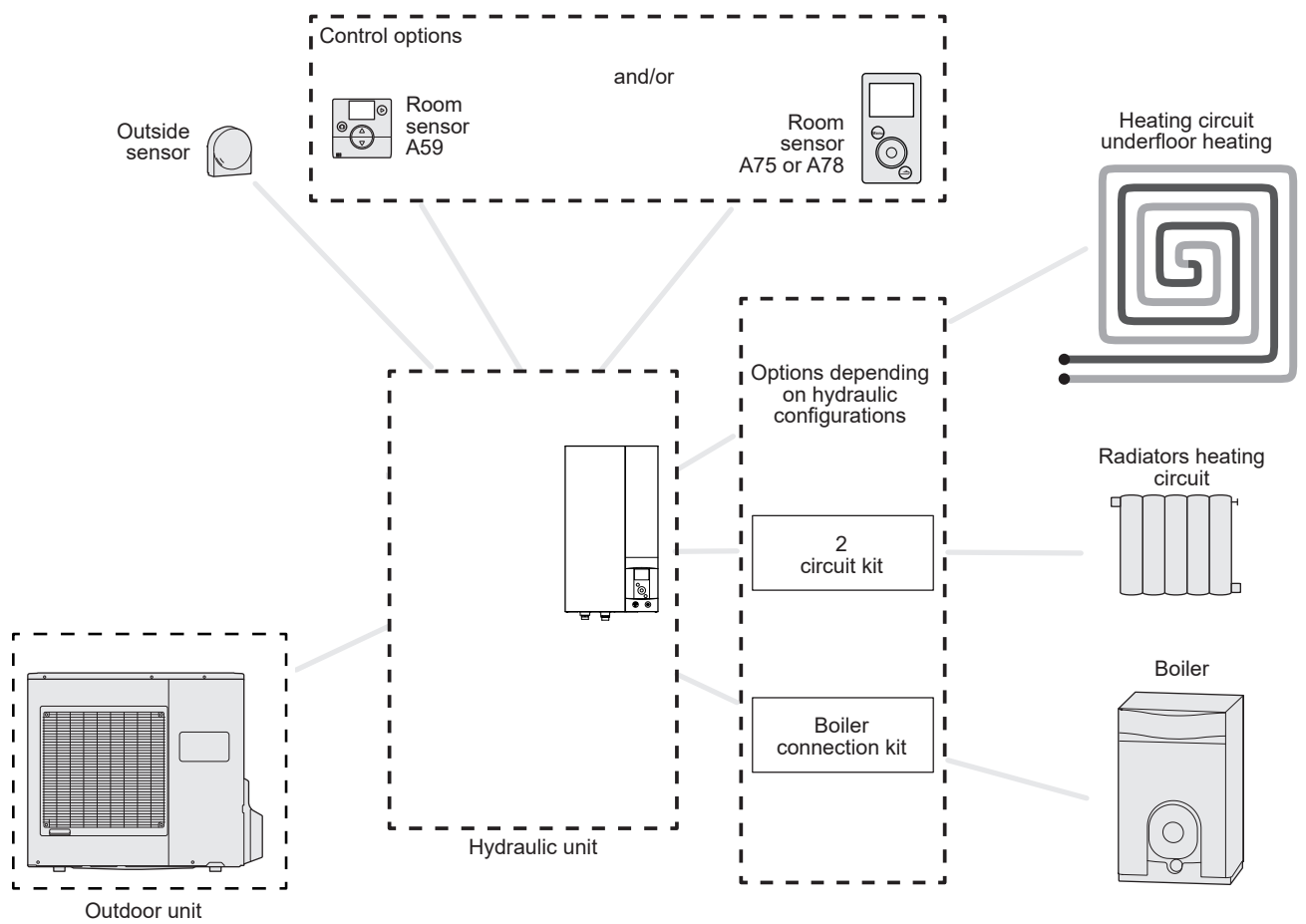

* depending on configuration / option

fig. 1 - Overview of complete installation configuration

Carrying out the installation

► User Interface

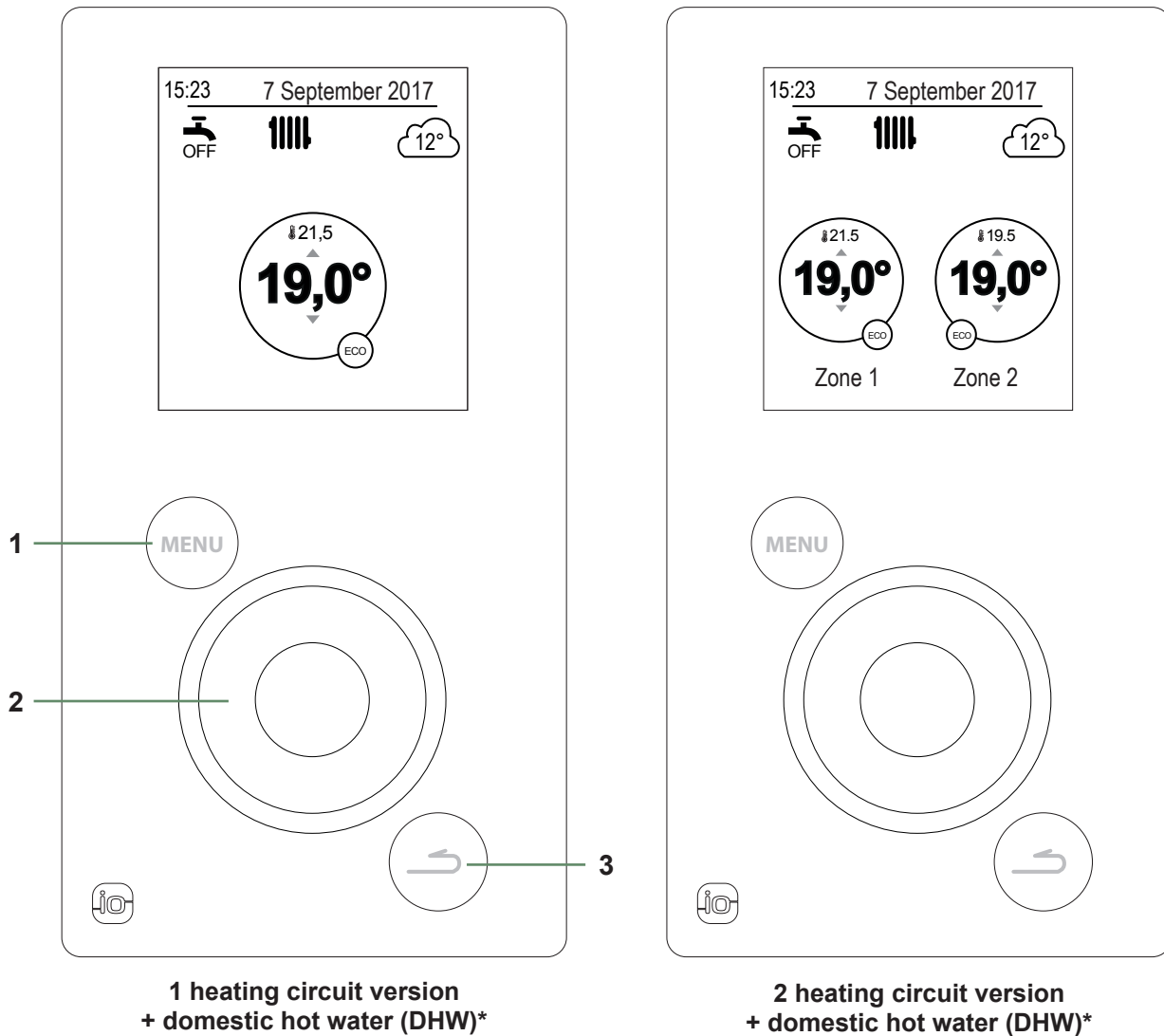

Reference	Description
1	Menu button
2	Navigation knob (rotate knob), accept (press knob)
3	Back button

* depending on configuration / option

► Display Description

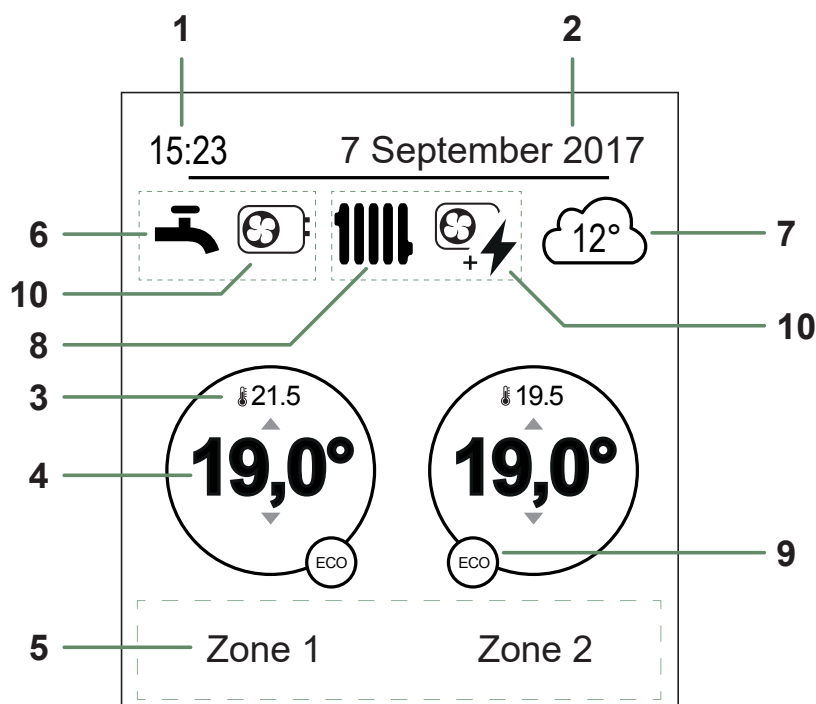





N°	Symbols	Definitions
1	15:23	Time
2	07 September 2017	Date
3	21.5	Temperature measured by the room sensor*
4	19,0°	Room temperature setpoint
5	Information (zone names, emergency mode, test mode, error display, etc.)	
6	Domestic Hot Water (DHW)* ...	
		Activated
		Boosting in progress
		Deactivated
7		Temperature measured by the outside sensor
8	Operation ...	
		Heating
		Cooling*

N°	Symbols	Definitions
9	Mode ...	
		Comfort
		Manual (exemption)
	ECO	ECO
		Holiday
		Floor drying
		Stop (except frost)
10	Production via ...	
		Heat Pump
		Electrical backup*
		HP + electrical backup*
		HP + Fuel/Gas*
		Fuel/Gas*

* depending on configuration / option

► Navigating the Menus

To ...	Action:
Access the menu	Press  .
Choose a menu item	Turn the knob to highlight your choice. Press the knob to accept.
Return to the previous menu	Press  .
Return to the main menu	Press  twice.
Return to the welcome screen	Press  or  on the main menu.

Note: Some settings (or menus) might not be displayed. They are dependent on the installation's configuration (and installed options).

► Modifying Settings

Turn the knob to highlight the setting you wish to change.

Press the knob to accept the change.

Turn the knob to adjust the setting.

Press the knob to accept your choice.

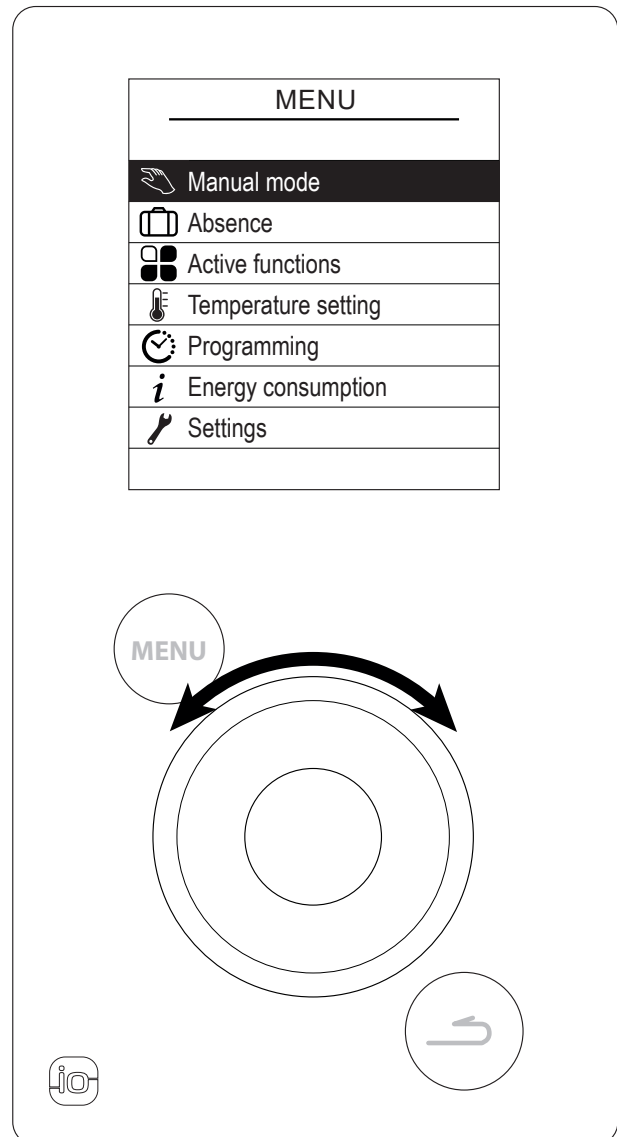

fig. 2 - Navigation

► Menu Structure



► Manual mode

▼ Derogation from timer program

When a timer program is active (advanced menu), an exemption allows you to force the appliance into operation ("Heating" or "Cooling") at the desired temperature for a certain duration.

■ From the welcome screen

Select the zone (the selected zone's circle is thicker).

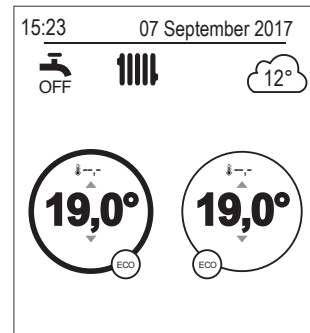

Set the required temperature, then the duration of the exemption.

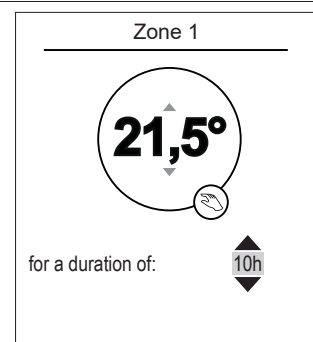

■ From the menu

Choose the zone from the menu:
"Manual mode".

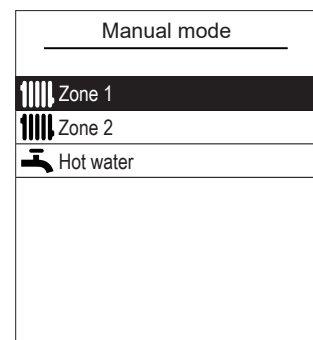

Set the required temperature, then the duration of the exemption.

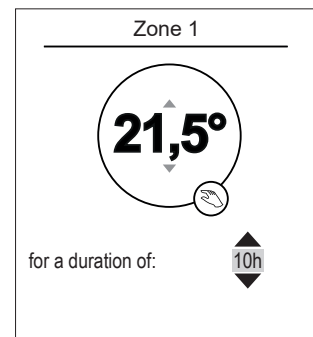

Some settings (or menus) might not be displayed. They are dependent on the installation's configuration (and installed options).

▼ Cancelling an derogation from timer program

■ Cancelling an derogation with 1 heating zone

From the welcome screen, select:
"Stop the derogation".

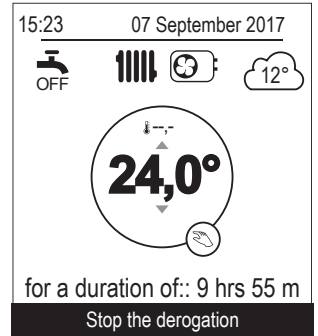

■ Cancelling an derogation with 2 heating zones

Choose the zone from the menu:
"Manual mode".
Press the knob to cancel the exemption.

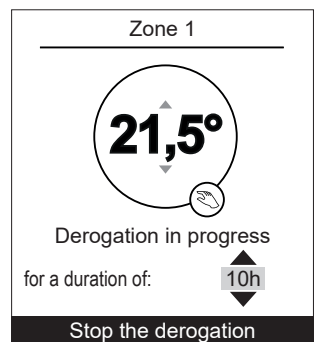

▼ Forced domestic hot water operation (Boost)

The domestic hot water (DHW) boost function heats the tank up to the Comfort temperature.

Go to the menu:
"Manual mode" > "Hot water".
Press the knob to activate the *"BOOST"* function.

**When hot water is required, the heat pump adapts its priority to meet the request.
No heating is produced during the preparation of domestic hot water.**

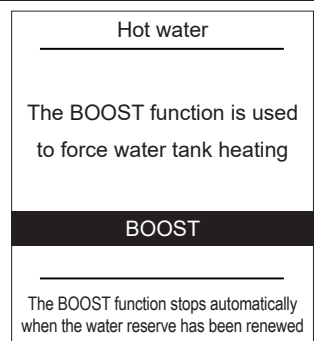

► Absence

In the event of a prolonged absence, you can set a period in which the heating operates at a reduced temperature (except for frost) and the production of domestic hot water (DHW) is stopped.

▼ Programming absence mode

Set the holiday start and end dates and accept.

- To return to the previous setting (e.g. from month to day), press the  button.

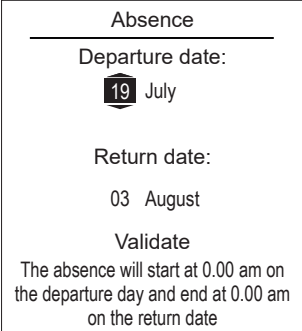

Absence

Departure date:
19 July

Return date:
03 August

Validate
The absence will start at 0.00 am on the departure day and end at 0.00 am on the return date

Set the temperature for the dwelling during the absence.

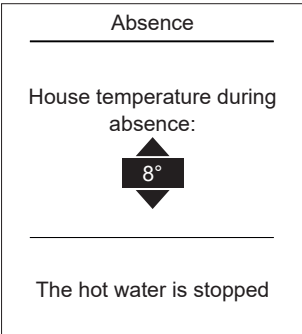

Absence

House temperature during absence:
8°

The hot water is stopped

▼ Viewing, modifying and cancelling the next absence period

You can view, modify and cancel the next holiday period by going into the menu: "Absence".

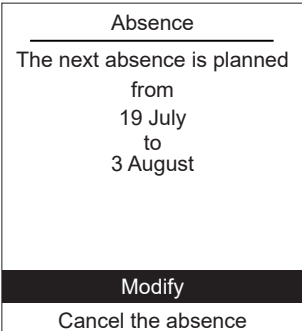

Absence



The next absence is planned from
19 July
to
3 August

Modify
Cancel the absence

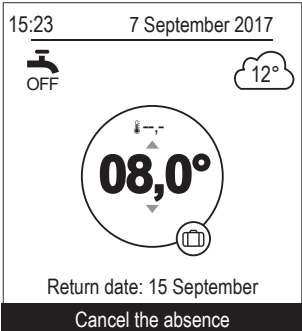
You can cancel a currently active absence period from the welcome screen.



15:23 7 September 2017

 OFF  12°

08,0° 

Return date: 15 September
Cancel the absence

Some settings (or menus) might not be displayed. They are dependent on the installation's configuration (and installed options).

▶ Active functions

The "Active Functions" page tells you which services are operating and allows you to change their status.

- "Indoor comfort": Heating / Cooling / Stop.

- "Zone 1" / "Zone 2" / "Hot water" / "Emergency operation": ON / Stop.

If "Indoor Comfort" is set to "Stop", Zones 1 and 2 cannot be modified.

"Emergency operation" : Activate only in case of error "370 : Thermodynamic Generator". The appliance heats only with the electrical backup.

Active functions	
Indoor comfort	Heating
Zone 1	ON
Zone 2	ON
Hot water	ON
Emergency operation	Stop

▶ Temperature setting

The "Temperature setting" page allows you to set temperature setpoints for Comfort and ECO periods (heating and cooling). Settings must be recorded for each zone.

Heating temperatures factory settings:

Comfort 20°C, ECO 19°C.

Cooling temperatures factory settings:

Comfort 24°C, ECO 26°C.

Temperature setting	
Zone 1	
Heating	
Comfort T°	21.5°C
ECO T°	21.5°C
Cooling	
Comfort T°	19.5°C
ECO T°	21.5°C

Some settings (or menus) might not be displayed. They are dependent on the installation's configuration (and installed options).

▶ Programming

A timer program allows you to define the appliance's automatic operation periods (Comfort ↔ ECO) Each day can be set independently.

▼ Creating a timer program

① - Choose "Heating" or "Cooling" as well as the appropriate zone by accessing the menu:
"Programming" > "Heating" / "Cooling" > "Zone 1" / "Zone 2".

② - Select the day.

③ - Adjust the Comfort period start and end times.

If 2 or 3 Comfort periods are not required, click on "--:--".

- To return to the previous setting (e.g. end 1st heating period to start of 1st heating period), press the  button.

• To copy the program to other days:

④ - Select "Validate and copy".

⑤ - Set the required days to "Yes" and then select "Complete".

• Else "Validate".

Heating / cooling period factory setting: 06:00 - 22:00.

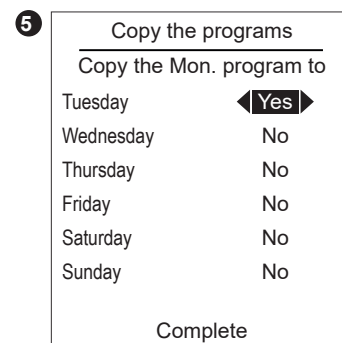
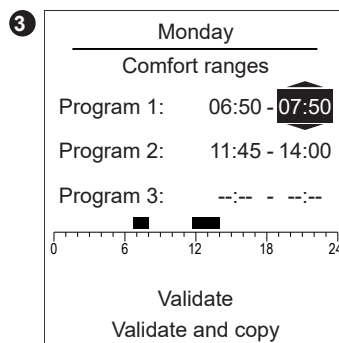
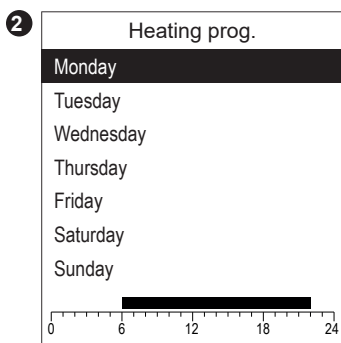

▼ Deleting a Comfort period

To delete a Comfort period, set its start and end times to the same value.

When accepting a setting, the screen displays:

Program X: --:-- - --:--

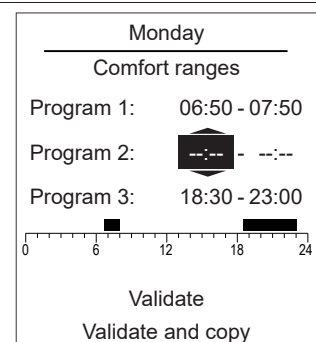

► *i* Energy consumption

Consumption can be displayed per usage:

- Heating (Zones 1 and 2).
- Cooling.
- Domestic Hot Water (DHW).
- Total (Heating + Cooling + Hot Water).

This information is available for:

- the last 8 days: daily consumption (Tdy = Today, D-1 = yesterday, etc.).
- the last 12 months: monthly consumption (Initial letter of month. e.g. J = January, etc.).
- the last 10 years: annual consumption (last 2 digits. e.g. 16 = 2016).

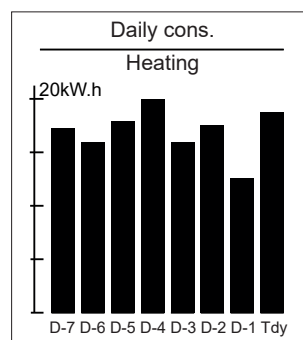

Example for daily consumption of the heating system.

► *⚙️* Settings

▼ Date and time

To set the appliance's date and time, access the menu:

"Settings" > "Date and Time".

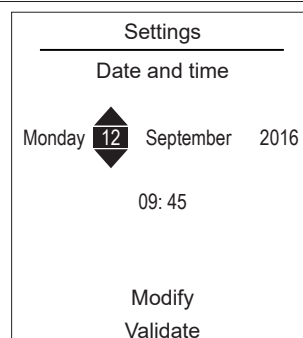

▼ Language

To change the language, access the menu:

"Settings" > "Language".

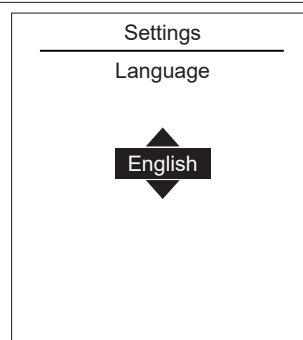

Some settings (or menus) might not be displayed. They are dependent on the installation's configuration (and installed options).

▼ Advanced/simplified menu

Two display modes for menus and appliance functions are available:

- **Advanced menu:**

- The appliance follows the timer programming defined in paragraph , *page 14*.

- **Simplified menu*:**

- The appliance operates at a constant temperature set directly by the user.
- Some functions are no longer accessible.

* The "Simplified Menu" setting is not compatible with the Cozytouch application.

Choose the display mode from the menu:

"Settings" > "Advanced/Simplified menu"

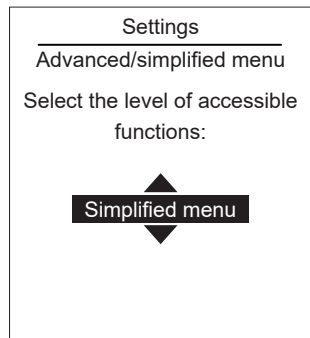

■ Setting the temperature in the Simplified Menu

1 zone

- ① - Turn the knob to adjust the temperature **directly**.

2 zones

- ② - Select the zone. Accept.
- ④ - Set the temperature using the knob. Accept.

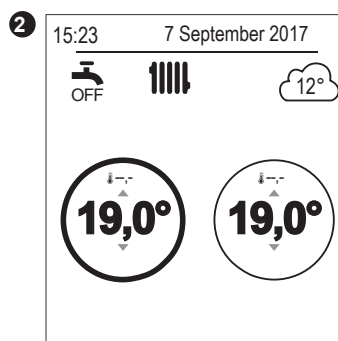
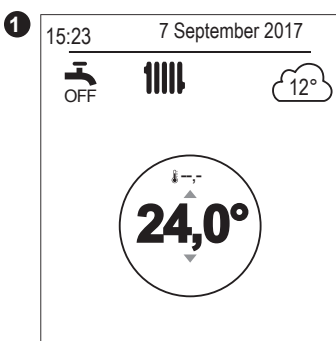

▼ Areas name

You can customise the zone names from the menu:

"Settings" > "Areas name".

Available names: "Area 1" / "Area 2" / "Day area" / "Night area" / "1st floor" / "Lounge" / "G. floor" / "Bedroom" / "Floor" / "Radiator".

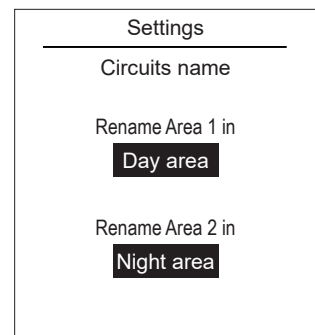

Some settings (or menus) might not be displayed. They are dependent on the installation's configuration (and installed options).

▼ Connectivities

■ Pairing a room sensor:

To connect a room sensor, go to the menu:
"Settings" > "Connectivities" > "Connection".
The appliance waits for pairing for 10 minutes.
See the room sensor's installation instructions.

The "Connection" menu is no longer accessible if a sensor has already paired.

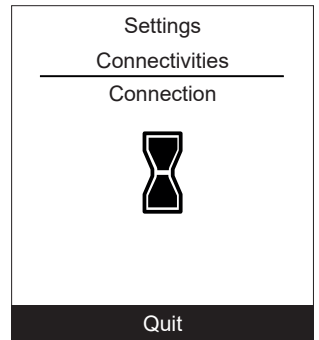

■ Reset connectivities

 Reinitialising will cancel all pairings.

Select "Re-set" in the menu:
"Settings" > "Connectivities" > "Reset connectivities".

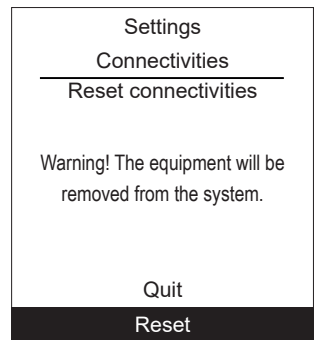

▼ Software version

Show the display (IHM) and controller software versions.

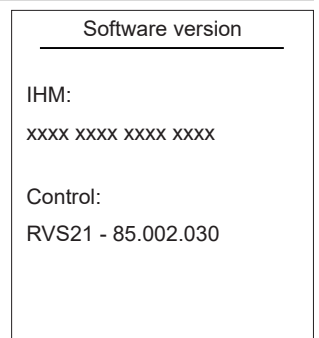

Some settings (or menus) might not be displayed. They are dependent on the installation's configuration (and installed options).

Maintenance

In order to ensure that your appliance operates correctly for many years, the maintenance operations described below are required periodically. They are generally carried out as part of a maintenance contract.

► Regular checks

Check the water pressure in the heating circuit regularly (refer to the installer's recommended pressure - between 1 and 2 bar)

If a filling operation and a pressure increase are required, check what type of fluid was used initially (when in doubt, contact your installer).

If frequent refills are required it is absolutely essential that you check for any leaks.



The frequent addition of water risks scaling the exchanger and affects its performance and lifespan.

► Checking the outdoor unit

Remove any dust from the exchanger, if necessary, while making sure not to damage the blades.

Check that there is nothing blocking the air flow.

► Domestic hot water tank*

Maintenance on the tank must be carried out regularly (frequency may vary according to water hardness).

Consult your heating engineer.

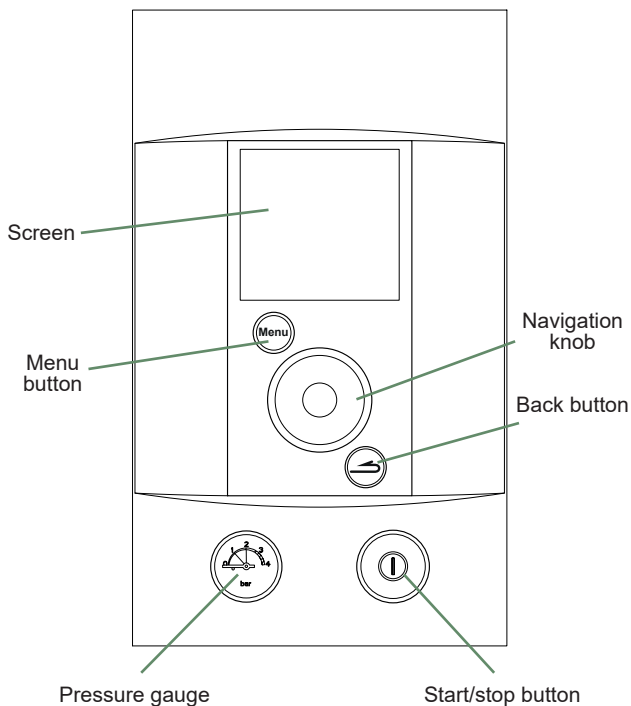

fig. 3 - Control panel

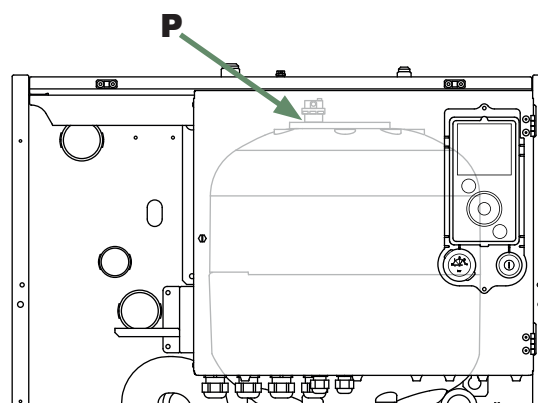
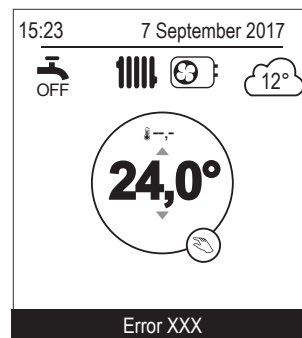

fig. 4 - Automatic bleeder valve

* depending on configuration / option

► Error messages

If a fault occurs, the error number appears on the welcome screen.



To obtain the error's designation, select it using the knob.

In the event of an error, note down the number and consult your heating engineer.

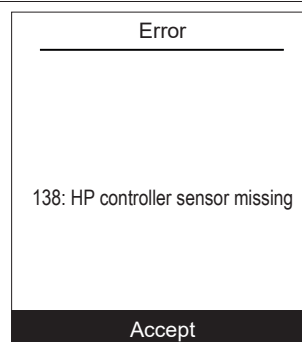

In case of error **"370 : Thermodynamic Generator"**, activate the **"Emergency operation"** (see [page 13](#)) and consult your heating technician

End-of-life of the appliance



The appliances must be dismantled and recycled by a specialised service. The appliances must not, under any circumstances, be thrown out with household waste, bulky waste or at a tip.

At the end of its service life, please contact your installer or local representative to proceed with its dismantling and recycling.



This unit is identified by this symbol. It means that all electrical and electronic products must not be included in household waste.

A specific recycling system for this type of product has been set up in European Union countries (*), Norway, Iceland and Liechtenstein.

Do not try to dismantle this product yourself. It may have damaging effects on your health or on the environment.

Reprocessing of the refrigerant, lubricant and other parts may be performed by a qualified installer in compliance with the local and national legislation in force.

This unit must be recycled by a specialised service and in no case may it be thrown away with household waste, rubble or in a landfill.

Please contact your installer or local representative for more .

* Depending on the national regulations of each member state.

Commissioning date:

Address of your heating installer or customer service.

ideal
HEATING

**idealboilers.com/
Ideal**

SATC - BP 64 - 59660 MERVILLE - FRANCE