

ideal
HEATING

Experts in heating for over 100 years.

Rated 'Excellent' on ★ Trustpilot with over 23,000 reviews.*



Made for Ireland



DISTRIBUTED BY

IDEAL
ENERGY

[idealenergy.ie](https://www.idealenergy.ie)

*as of October 2022

experts in heating.



Made for
Ireland



Market leading
warranties



Year round
customer support

At Ideal Heating, we are experts in domestic heating and hot water solutions. The last thing you should worry about is your boiler, therefore we rigorously test each and every one of our products with dozens of safety and reliability checks before they leave our Yorkshire based factory. This is why we confidently offer industry leading warranties on our boilers so we can go the extra mile for our customers.



Contents

- 4 - Ideal boiler type
- 6 - Our Products
- 15 - The Heat pump collection
- 37 - Atlantic collection
- 46 - Energy Efficiency
- 50 - Customer Service

Which type of boiler is **ideal** for your home?

System

Boiler + Cylinder



The Vogue MAX IE and Logic MAX IE models are available in the Ideal System range. Both are perfect for homes with multiple bathrooms.



System boilers are suited to homes with multiple bathrooms and can provide a constant supply of hot water to numerous taps at once.



System boilers require a cylinder to store hot water, however, they don't require a feed/expansion tank, so they are ideal for larger properties with little or no loft space.

Combi

Boiler only



Our Combi range includes our award winning Logic MAX Combi IE and the unrivalled premium Vogue MAX Combi IE boiler. Both models come in a range of outputs meaning they can heat homes of various sizes.



A Combi boiler is perfect for a small to medium sized property, providing mains pressure hot water on demand with no need for a hot water cylinder or feed/expansion tank. They are the full package in one compact unit supplying

heat to your radiator system, and hot water. Combi boilers are extremely efficient as they only heat water when it is needed, reducing bills and your household's carbon footprint.

Heat only

Boiler + Cylinder + Water feed tanks



The Logic MAX Heat IE comes with a 10 year parts and labour warranty and is compatible with a range of cylinders. Perfect for the replacement of most traditional boilers.



Heat only boilers are perfect for homes with multiple bathrooms, or where there is a large demand for hot water at once.



They are often thought of as a traditional boiler. They work alongside a separate hot water cylinder which is usually found in an airing cupboard, and a feed/expansion tank often found in the loft, so they are ideal for homes that already have a heat only boiler.

THE NEW LOGIC MAX IE

With over four million Logic boilers sold in the UK and IE, it has the reputation as one of the most reliable boilers available. We back this up with our 10 year warranty as standard for the Logic MAX IE.

System: 15, 18, 24, 30

Combi: 24, 30, 35

Heat: 12, 15, 18, 24, 30



OVER A DECADE OF INNOVATION

For over a decade our Logic range has been heating homes all over Ireland. In April 2022 we built our four millionth Logic boiler meaning we will be providing reliable warmth to millions of people for years to come.

First launched in 2009 the Logic range represents over 100 years of our advancement in heating technology. Our time served experience and products can give you peace in mind.



WE BELIEVE IN A QUIET HOME

The Logic MAX Combi IE has been awarded the Quiet Mark, and is one of only a very small number of boiler ranges to have achieved this.



Compact cupboard fit



Large colour screen and simple user interface



Quick and easy to install and service



Sleek modern design



Enhance boiler performance with Halo



Providing you with confidence and peace of mind the Logic MAX IE has a full parts and labour warranty for 10 years. Which demonstrates just how confident we are in the quality and reliability of our boilers.



PROTECTING YOUR HEATING SYSTEM

The Logic MAX IE comes with an Ideal System Filter in the box. Our System Filter has been proven to ensure long lasting protection of the boiler and heating system with no compromise on performance.



Quality forged brass construction with nickel plating



Powerful neodymium magnetic assembly

SYSTEM, COMBI OR HEAT?

Our Logic MAX IE range comes in both System, Combi and Heat only models with a wide range of outputs.

A Logic MAX Combi IE is great for homes with a family bathroom and average hot water usage. With outputs up to 35kW it is perfect for making sure every corner of your home is warm.

The Logic MAX System IE is ideal for homes with multiple bathrooms and large hot water demand. Available from 15kW up to 30kW there is Logic MAX System available to homes of any size.

If your home has a water tank and hot water cylinder the Logic MAX Heat IE could be ideal.

LOGIC MAX IE OUTPUTS

System:	Combi:	Heat:
- 15kW	- 24kW	- 12kW
- 18kW	- 30kW	- 15kW
- 24kW	- 35kW	- 18kW
- 30kW		- 24kW
		- 30kW

DIMENSIONS & CLEARANCES

All dimensions in mm

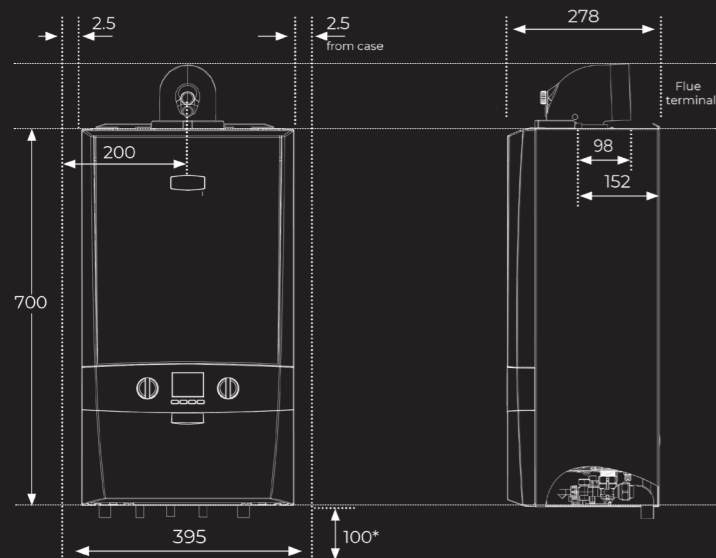

Note: The minimum front clearance when built into a cupboard is 5mm from the cupboard door but 450mm overall clearance with the cupboard door open is required for servicing.
*Bottom clearance after installation can be reduced to 5mm. However, 100mm is required for servicing. Rear flue option Logic MAX Heat only.



System available up to 30kW



Combi available up to 35kW



*Combi only



THE IDEAL COMBINATION

Combine our Logic MAX Combi IE with our Halo Combi Wi-Fi thermostat to increase the ErP package label rating to an A+.

VOGUE MAX IE

Over a century of heating innovation has led to one thing: the Vogue MAX IE.

A combination of sleek aesthetics and best in class components means the Vogue MAX IE sits at the pinnacle of the Ideal range with an impressive 12 year warranty*.

System: 15, 18, 26, 32
Combi: 26, 32, 40



MADE FOR IRELAND

First created at our factory in Yorkshire, the Vogue MAX IE has been designed, developed and built in the UK. Each year we invest into our UK based research and development facility ensuring our boilers are at the cutting edge of heating technology.



AWARD WINNING BOILERS

Our boilers have been awarded Good Housekeeping Reader Recommended status for seven consecutive years, for ease of use and low noise levels amongst other outstanding product details that left customers wanting to recommend Ideal Heating to their friends and families.



Premium components



Easy to use full colour display



Simple to install and service



Stylish aesthetics



Enhance boiler performance with Halo



The Vogue MAX System IE is our unrivalled premium combi boiler, designed and built with best in class components, including a quality stainless steel heat exchanger for your peace of mind.



PROTECTING YOUR HEATING SYSTEM

The Vogue MAX IE comes with an Ideal System Filter in the box. Our system filter has been proven to ensure long lasting protection of the boiler and heating system with no compromise on performance.



Quality forged brass construction with nickel plating



Powerful neodymium magnetic assembly

SYSTEM OR COMBI?

Our Vogue MAX IE range comes in both System or Combi models in a range of outputs.

The Vogue MAX System IE is ideal for homes with multiple bathrooms and large hot water demand. Available from 15kW up to 32kW there is Vogue MAX System IE available homes of any size.

A Vogue MAX Combi IE is great for homes with a family bathroom and average hot water usage. With outputs up to 40kW it is perfect for large homes making sure every corner of your home is warm.

VOGUE MAX OUTPUTS

System:	Combi:
- 15kW	- 26kW
- 18kW	- 32kW
- 26kW	- 40kW
- 32kW	

DIMENSIONS & CLEARANCES

All dimensions in mm

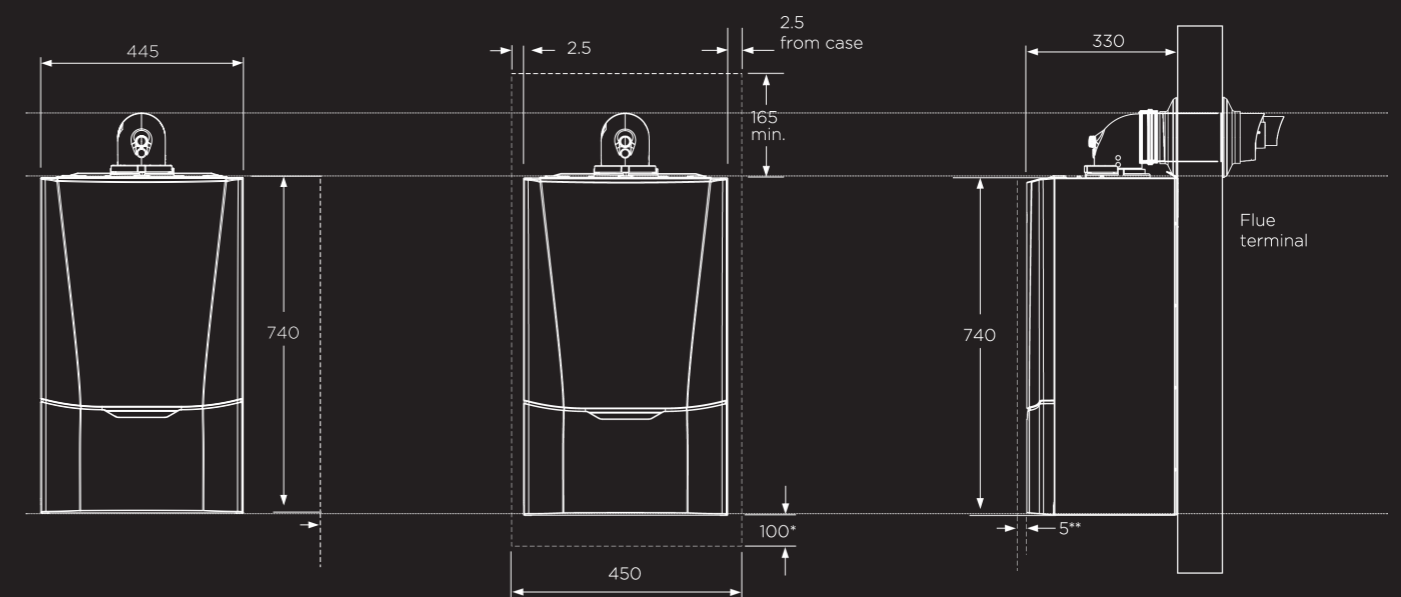

Note: The minimum front clearance when built into a cupboard is 5mm from the cupboard door but 450mm overall clearance with the cupboard door open is required for servicing.
*Bottom clearance after installation can be reduced to 5mm. However, 100mm is required for servicing.



System available up to 32kW



Combi available up to 40kW

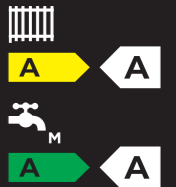

*Combi only



Logic IE

4
MILLION

4 MILLION SOLD

With over 4 million Logic boilers sold in the UK and IE, the range has built a reputation as one of the easiest to install and work on.

The Logic IE has received Good Housekeeping Reader Recommendation for seven years in a row along with Quiet Mark recognition on the Logic System IE and Logic Combi IE.

A
EFFICIENCY RATING



LOGIC IE OUTPUTS

SYSTEM	HEAT	COMBI
- 15kW	- 12kW	- 24kW
- 18kW	- 15kW	- 30kW
- 24kW	- 18kW	- 35kW
- 30kW	- 24kW	
	- 30kW	



HALO

RANGE OF SMART ROOM THERMOSTATS

Halo Wi-Fi

Halo Wi-Fi comes with some great benefits, including app-controlled heating which gives you full control of your heating through your phone or device. Halo is also compatible with Amazon Alexa and Google Home, allowing you to control your heating and find out the temperature, all with your voice.

Halo Wi-Fi comes in a Heat & System and Combi range.



2
YEAR WARRANTY*



BENEFITS OF HALO WIFI



Designed specifically to work with Ideal boilers



A simple dial and button interface that's easy for everyone to use



Smart home compatible - control your heating with Amazon Alexa or Google Home*

A+

A+ energy efficiency rating achieved by fitting Halo Combi Wi-Fi with our Logic MAX Combi IE boiler



Easy app set up walk through to get started



Large, clear, colour screen



Geolocation for lifestyle based heating*

*10 year warranty when installed with an Ideal System Filter. 7 years parts and labour warranty as standard. Terms and conditions apply.

HALO

Halo 2-Zone Extension Kit

Enjoy the benefits of a multi-zone heating with the Halo 2-Zone Extension kit.

The Halo 2-Zone Extension kit is available for Halo Wi-Fi, offering an extra level of heating control. Split your home into two separate zones of heating, setting a separate heating schedule and temperature range for the second zone. So if you're spending your days downstairs, you can set your upstairs heating to come on later helping to save energy.

The Halo 2-Zone Extension kit is fully modulating on both heating zones, helping to save energy usage.

ADDITIONAL BENEFITS OF THE HALO 2-ZONE EXTENSION KIT



Designed specifically to work with Ideal boilers



2nd space heating zone control



Fully modulating through enhanced load compensation on both zones to reduce energy consumption



ideal
HEATING

Logic Air monobloc heat pump.

4kW - 10kW



Introduction, background and collaboration.

Whilst we may be best known for gas boilers in IE, behind the scenes there is a wealth of expertise reaching across the globe supporting the **low carbon transformation** that is coming to the IE heating industry.

Our parent company, Groupe Atlantic, a family-owned global HVAC manufacturer, has a long history in heat pumps and currently holds a market leading position in France. Combining the Groupe Atlantic heat pump technical and manufacturing expertise with our knowledge of the UK and IE heating systems and the UK and IE market provides a **winning formula for the launch of our first monobloc heat pump range.**



Combining knowledge and skills from Groupe Atlantic and Ideal Heating, we have developed **a range of products that will make our customers lives easier**, just like the award-winning Logic boiler.

As well as the technical and manufacturing expertise, the **new low carbon products** are supported by the industry leading customer support package that we are known for. From heating design support to technical assistance, over the phone or in person including end user advice, whether the product is a heat pump or a gas boiler, we will deliver the same outstanding customer service and support.

Therefore, we are pleased to announce the launch of the Logic Air monobloc heat pump, pre plumbed heat pump cylinder and Halo Air room thermostat.



The Ideal heat pump ecosystem.

The Logic Air range brings our best low carbon products together. Designed to operate seamlessly, our industry leading heat pump, highly efficient hot water cylinder and Halo room thermostat provide all the components

for a reliable and efficient heat pump system. Supported by national customer service and engineer support. The Logic Air range offers the complete low carbon package.



Logic Air heat pump.



KEY FEATURES



Easy to install
and service



Year round
customer support



SCOP rating
up to 519%*



Quiet
operation



Hot water in
sunshine, rain,
ice and snow



All Logic Air heat
pumps are Quiet
Mark certified



Logical solutions.



EFFICIENCY

The efficiency rating of a heat pump determines how much it costs to use. A high efficiency rating means it costs less to operate. The Logic Air has one of the highest efficiency ratings in IE, rated at 5.19 (Coefficient of performance) making it one of the most economical heat pumps on the market.



SOUND AND DIMENSIONS

Sound and dimensions are important, not just for our customers comfort level. The Logic Air is quiet and compact. Cutting edge acoustic technology makes its low sound levels amongst the best in the market.



FAST HEAT PUMP INSTALLATION

Our Logic Air heat pump, pre-plumbed cylinders and Halo Air room thermostat are designed to be amongst the fastest heat pumps to install. Factory fitted components, click and connect wiring terminals reduce installation time and improve installation reliability.



HOT WATER

Ensuring enough hot water can be generated efficiently and quickly is crucial to a heat pump system. The Logic Air pre-plumbed hot water cylinder can generate hot water faster than some of the most popular heat pump DHW cylinders in IE, saving money and energy.



SIMPLE TO USE, APP CONTROL AND ONLINE HEALTH CHECKS

Halo Air is a new generation of heat pump thermostats connected to your phone with options to connect to our customer service team. Halo Air automatically makes your heating system more efficient, enables remote control and 24/7 system performance data. All wrapped up in an easy to use controller.



SAFE AS STANDARD

R32 refrigerant has a flammability rating almost 85% lower than propane alternatives. With a '0' ozone depletion rating and a low global warming potential, R32 is safe efficient and reliable.

Logic Air pre-plumbed cylinder.



KEY FEATURES



150ltr - 300ltr options



Control box included



Fully pre-plumbed and pre-wired



Industry leading reheat times



Built in low loss header or buffer tank

Logic Air control box.



The Logic Air control box is the central hub for the heat pump system, linking the heat pump to your heating and hot water cylinder. It enables in depth control, scheduling, connectivity and performance diagnostics.

INBUILT HEAT PUMP CONTROLLER

Our inbuilt controller uses tried and tested technology to keep you warm efficiently. From scheduling to diagnostics our controller gives you control and transparency.

QUICK START SET UP

Our new quick start menu makes commissioning fast, easy and accurate. In just a few steps the heat pump can be up and running and tuned to its most efficient parameters.

HYBRID READY

For installations that require a heat pump and a boiler, the Logic Air control box brings a boiler and heat pump together seamlessly.

CONNECTIVITY

The Logic Air control box is compatible with Halo Air, Link Cellular heat pump diagnostics and 3rd party thermostats, giving you access to online control, scheduling and remote diagnostics from anywhere in the world.

SMART GRID COMPATIBLE / SOLAR PV COMPATIBLE

The Logic Air control box is smart grid ready and can connect to solar PV, enabling smarter ways of powering heating and hot water.

PERFORMANCE DIAGNOSTICS

The Logic Air control box gives you access to the efficiency of the householders heating system, helping them to understand the health of their heat pump system at a glance.



Accessories list.



FLEXIBLE HOSE

Flexible Hose 500mm

- 28mm -1" Female connections pair (2x hose)
- Pre-insulated (19mm PVC)
- Stainless steel

Flexible Hose 750mm

- 28mm -1" Female connections Pair (2x hose)
- Pre-insulated (19mm PVC)
- Stainless steel

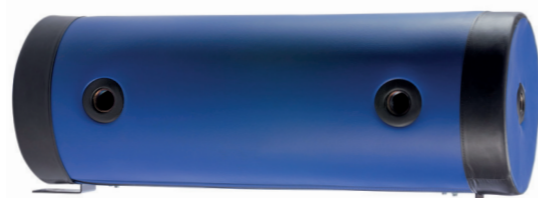

BUFFER TANK

25L Buffer Tank

- 1" and 1 1/4" connections
- 6 bar max. pressure

50L Buffer Tank

- 1" and 1 1/4" connections
- 6 bar max. pressure



MAGNETIC FILTER

- 28mm connections
- 4 bar max. working pressure



LINK DIAGNOSTICS CELLULAR HEAT PUMP

- Remote Diagnostics
- Online Dashboard
- Designed for Logic Air
- 10 year data plan included

ACCESSORIES FOR OUTDOOR UNIT.

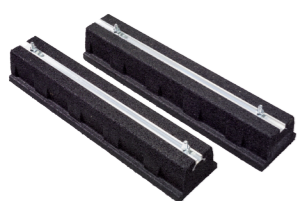

ANTI-VIBRATION RUBBER MOUNTING FEET

- Rubber feet
- Pair (x2)
- 600mm



FILTER BALL VALVE

- 1" connections
- 30 bar max. pressure
- Brass – chrome plated body
- Stainless steel & Nylon filter



Y STRAINER

- 1" connections
- 16 bar max. pressure
- Brass body
- Stainless steel strainer

HALO

AIR

IDEAL HALO AIR Wi-Fi & RF



*2 year parts and labour warranty available when registered within 30 days of installation. Terms and conditions apply.

KEY FEATURES



Designed for
Logic Air



Easy to install



Full heating and
hot water control



Halo Air introduction.

Halo Air is a programmable room thermostat, based on the current Ideal Halo platform that is designed and developed to work seamlessly with the new Logic Air monobloc heat pump.

As the primary interface with the end user for the whole heating system it is important that the room thermostat is clear, easy to use and guides the right usage behaviour.

Halo Air not only provides a clear user interface for the householder but it helps to communicate diagnostic data to the installer or service help desk.

HALO AIR RF.



HALO AIR WI-FI.



HALO AIR 2 ZONE RF.



HALO AIR 2 ZONE WI-FI.



Halo Air RF.



YEAR WARRANTY*



2 year warranty



Easy to install



Load compensating control



Compatible with Logic Air



Simple wiring connections to heat pump control box



Simple dial and button interface

Halo Air RF is a wireless programmable room thermostat designed specifically to work with Logic Air.

Halo Air offers fast, flexible and intelligent wireless technology and is packed with features that enable simple and easy heating and hot water control.

*2 year parts and labour warranty available when registered within 30 days of installation. Terms and conditions apply.

Halo Air Wi-Fi.



YEAR WARRANTY*



2 year warranty



Smart home compatible



Control your heating and hot water anywhere via the app



Compatible with Logic Air



Easy to install



Year round customer support



Easy app set up



Load compensating control

Halo Air Wi-Fi is engineered specifically to work with Logic Air heat pumps and allows flexible control of heating and hot water with the intuitive Halo app, which can be connected through smart home devices like Amazon Alexa and Google Home.

It's simple to install, straightforward for everyone to use, no matter where they are.

*2 year parts and labour warranty available when registered within 30 days of installation. Terms and conditions apply.

Halo Air 2-Zone RF.



2-Zone control



Easy to install



Load compensating control



Compatible with Logic Air



Simple wiring to heat pump control box



Simple dial and button interface

Halo Air RF 2-Zone incorporates an additional programmable room thermostat with the extra functionality of controlling the temperature of a second zone.

*2 year parts and labour warranty available when registered within 30 days of installation. Terms and conditions apply.

Halo Air 2-Zone Wi-Fi.



2-Zone control



Smart home compatible



Control your heating and hot water no matter where you are



Compatible with Logic Air



Easy to install



Year round customer support



Easy app set up



Load compensating control

Halo Air Wi-Fi 2-Zone incorporates an additional programmable room thermostat with the extra functionality of controlling the temperature of a second zone.

*2 year parts and labour warranty available when registered within 30 days of installation. Terms and conditions apply.

Halo Air features.

HALO AIR IS A BATTERY POWERED, WIRELESS CONTROL FOR BOTH HEATING AND HOT WATER.

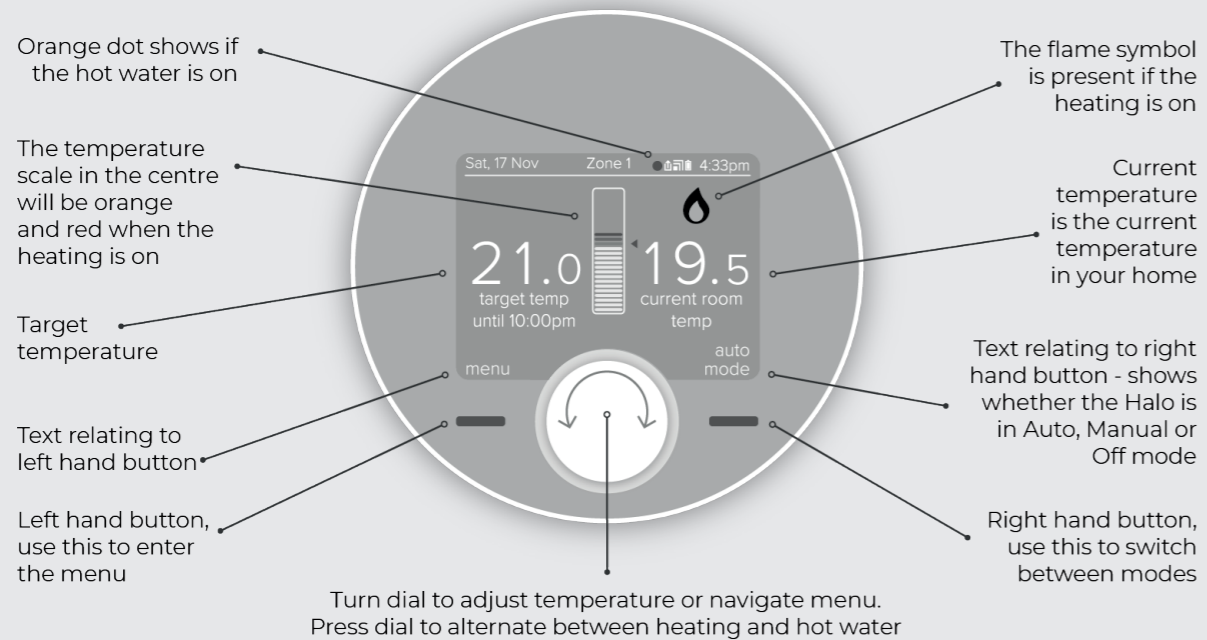

HALO AIR SMART INTERFACE

The Halo Air smart interface connects the heat pump to the Wi-Fi and the Halo thermostat(s)

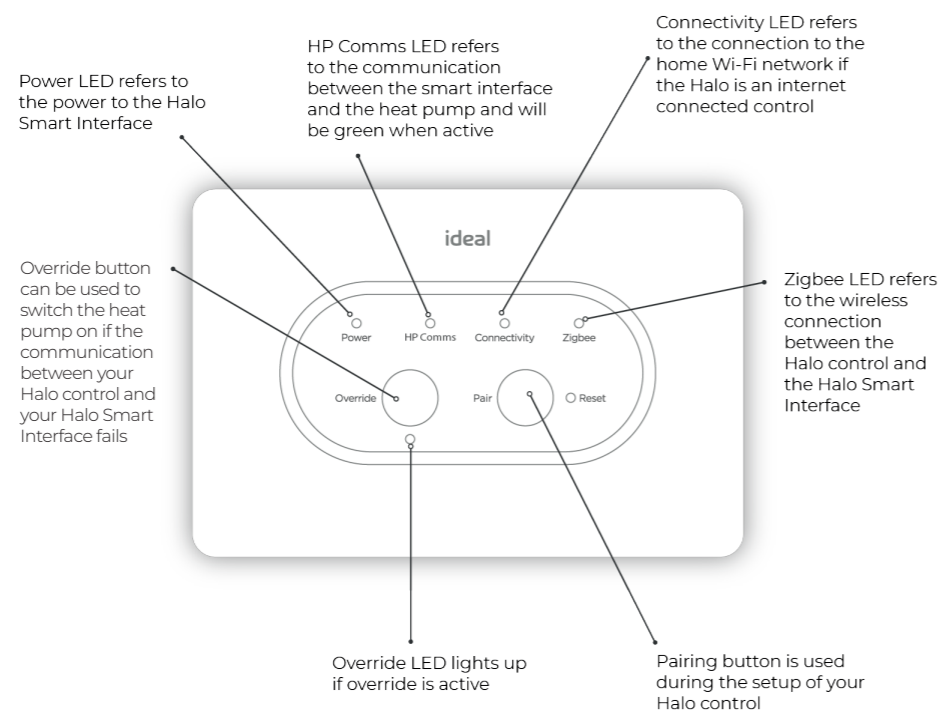

Designed for new builds.



MONOBLOC TECHNOLOGY

- Modern contemporary chassis design
- Quiet acoustics
- Easy to install and service
- Simple to commission
- Designed for Halo Air



DHW PERFORMANCE MATTERS

- Designed to work with Logic Air pre-plumbed cylinders
- Highly efficient hot water production
- Fast reheat times for reduced energy usage
- Low pressure losses ensure good heat pump modulation



GOING GREEN WITHOUT COMPROMISE

- Built to be efficient with an A+++ ErP rating
- Capacities to work in the IE climate
- R32 refrigerant with zero ozone depletion and low global warming potential
- Integrates with solar PV and smart grid technologies



Atlantic Alfea Extensa R32

Split air-to-water heat pump that provides a low temperature solution for all projects

PRODUCT OVERVIEW

- Suitable for New Builds & Renovations
- 4 Models: 5kw - 10kw outputs (single phase)
- COP: up to 4.74 (+7°C / +35°C)
- Outside working temperatures -20°C to +35°C
- Low Temperature Heating
- NZEB Compliant
- Market Leading 8 Year Warranty
- Reliability as Standard

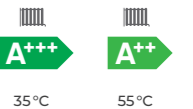
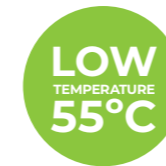

Designed for home owners.



USER FRIENDLY

- Simple user controls
- Low running costs
- Easy maintenance and installation
- Engineered for reliability



INDUSTRY LEADING CUSTOMER SERVICE

- In house heat pump design team
- Nationwide service engineers
- IE customer service contact centre
- Online warranty registration with Connect



CUTTING EDGE TECHNOLOGY

- Auto Adapt - Autopilot for your heating
- Engineered for reliability
- Remarkably quiet

KEY FEATURES

- Patented Co-axial Heat Exchanger
- Robust System tolerant heat exchanger with large waterways
- Built in 16lt Buffer Tank
- Intuitive and simple to use controls
- Easy Installation & maintenance
- Compatible with all low temperature heating emitters (underfloor heating, steel panel radiators, aluminium radiators, fan coils)
- Integrated electrical back-up heater
- Navistem 400S Controller - Quick Start Set Up
- Cozy Touch app enables the heat pump to be controlled remotely from a smartphone or tablet (Optional)
- Low Energy Consumption circulating pump
- Inverter modulation
- Twin Rotary Compressor
- Refrigerant circuit
- Accessories to meet all installation requirements

ACCESSORIES

- Duo 2 Zone Kit - incl. Pump, Pipework & Mixing Valve. This allows the underfloor and radiators to be run at a different temperature simultaneously.
- Hydraulic stand off kit for top connections
- Boiler connection kit
- A59 Navilink stat
- DHW Kit
- Buffer Tank 25ltr
- Buffer Tank 50ltr
- Cozy Touch Gateway

Atlantic Alfea Extensa Duo R32

Split air-to-water heat pump that provides a low temperature solution (heating & DHW) for all projects

PRODUCT OVERVIEW

- Suitable for New Builds & Renovations
- 4 Models: 5kw - 10kw outputs - single phase
- Integrated Heating & DHW Indoor Unit
- COP: up to 4.74 (+7°C / +35°C)
- Outside working temperatures -20°C to +35°C
- Low Temperature Heating
- NZEB Compliant
- Market Leading 8 Year Warranty
- Reliability as Standard



KEY FEATURES

- Patented Co-axial Heat Exchanger
- Robust System tolerant heat exchanger with large waterways
- No waterflow controller needed - reducing circulation issues
- Built in 16lt Buffer Tank
- Domestic Hot Water (DHW) storage tank integrated (190L)
- Intuitive Controls & Simple to use
- Easy Installation & maintenance
- Compatible with all low temperature heating emitters (underfloor heating, steel panel radiators, aluminium radiators, fan coils)
- Integrated electrical back-up heater
- Navistem 400S Controller - Quick Start Set Up
- Cozy Touch app enables the heat pump to be controlled remotely from a smartphone or tablet (Optional)
- Low Energy Consumption circulating pump
- Inverter modulation
- Twin Rotary Compressor
- Refrigerant
- Accessories to meet all installation requirements



ACCESSORIES

- Duo 2 Zone Kit - incl. Pump, Pipework & Mixing Valve. This allows the underfloor and radiators systems to be run at a different temperature simultaneously.
- Hydraulic stand off kit for top connections
- Boiler connection kit
- A59 Navilink stat
- DHW Kit
- Buffer Tank 25ltr
- Buffer Tank 50ltr
- Cozy Touch Gateway

Atlantic Alfea Excellia

Split air-to-water heat pump that provides a high temperature solution for all projects.

PRODUCT OVERVIEW

- Suitable for New Builds & Renovations
- 3 Models: 11kw, 14kw & 16kw outputs
- Three phase available in 16kw
- COP: up to 4.25 (+7°C / +35°C)
- Outside working temperatures -25°C to +35°C
- High Temperature Heating up to 60°C
- NZEB Compliant
- Market Leading 8 Year Warranty
- Reliability as Standard



KEY FEATURES

- Patented Co-axial Heat Exchanger
- Robust System tolerant heat exchanger with large waterways
- No in line filter required - less maintenance
- No waterflow controller needed - reducing circulation issues
- Built in Buffer Tank
- Intuitive and simple to use controls
- Easy Installation & maintenance
- Compatible with all low temperature heating emitters (underfloor heating, steel panel radiators, aluminium radiators, fan coils)
- Integrated electrical back-up heater
- Navistem 400S Controller - Quick Start Set Up
- Cozy Touch app enables the heat pump to be controlled remotely from a smartphone or tablet (Optional)
- Low Energy Consumption circulating pump
- Inverter modulation
- Twin Rotary Compressor
- Refrigerant circuit R410A
- Accessories to meet all installation requirements



ACCESSORIES

- Duo 2 Zone Kit - incl. Pump, Pipework & Mixing Valve. This allows the underfloor and radiators systems to be run at a different temperature simultaneously.
- Hydraulic stand off kit for top connections
- Boiler connection kit
- A59 Navilink stat
- DHW Kit
- Electrical relay available to upgrade Electrical back up to 6kw & 9kw (on 3 phase)
- Buffer Tank 25ltr
- Buffer Tank 50ltr
- Cozy Touch Gateway

Atlantic Alfea Excellia Duo

Split air-to-water heat pump provides a high temperature solution (heating & DHW) for all projects.

PRODUCT OVERVIEW

- Suitable for New Builds & Renovations
- 3 Models: 11kw, 14kw & 16kw outputs
- Three phase available in 16kw
- COP: up to 4.3 (+7°C / +35°C)
- Outside working temperatures -25°C to +35°C
- High Temperature Heating up to 60°C
- NZEB Compliant
- Market Leading 8 Year Warranty
- Reliability as Standard



KEY FEATURES

- Patented Co-axial Heat Exchanger
- Robust System tolerant heat exchanger with large waterways
- No waterflow controller needed - reducing circulation issues
- Built in Buffer Tank
- Intuitive and simple to use controls
- Easy Installation & maintenance
- Compatible with all low temperature heating emitters (underfloor heating, steel panel radiators, aluminium radiators, fan coils)
- Integrated 190ltr DHW Storage Tank
- Integrated electrical back-up heater
- Navistem 400S Controller - Quick Start Set Up
- Cozy Touch app enables the heat pump to be controlled remotely from a smartphone or tablet (Optional)
- Low Energy Consumption circulating pump
- Inverter modulation
- Twin Rotary Compressor
- Refrigerant circuit R410A
- Accessories to meet all installation requirements



ACCESSORIES

- Duo 2 Zone Kit - incl. Pump, Pipework & Mixing Valve. This allows the underfloor and radiators systems to be run at a different temperature simultaneously.
- Hydraulic stand off kit for top connections
- Boiler connection kit
- A59 Navilink stat
- DHW Kit
- Electrical relay available to upgrade Electrical back up to 6kw & 9kw (on 3 phase)
- Buffer Tank 25ltr
- Buffer Tank 50ltr
- Cozy Touch Gateway

Atlantic Alfea A.I R32 Range Accessories



NAVILINK A59

- Room temperature display
- Radio communication
- Wired or wireless installation
- Simple activation for holiday mode



BOILER CONNECTION

- Allows the connection of a gas or oil boiler to the Heat Pump
- Compatible with the 2 zone kit
- Provides system flexibility to cover all installations

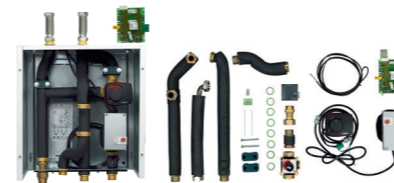

2 ZONE KIT (SINGLE SERVICE & DUO UNIT)

- Compact 2 zone kit
- Integrated low consumption circulation pump and mixer valve
- Compatible with underfloor heating, radiators and fan coil heating systems



BUFFER TANK

- Compact and versatile buffer tank
- Wall hung installation in either vertical or horizontal position
- Available in 25 & 50 litre capacities

ACCESSORIES FOR OUTDOOR UNIT



White PVC floor support (x2)



Black rubber floor support (x2)



Wall bracket 560mm (with bar)



Heater for drain pan

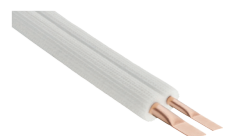

Refrigerant pipes



Protection pipes for refrigerant pipes

F127

PANEL HEATER

The Atlantic F127 electric panel heater utilises convection heating to quickly warm any room and, with its simple cosmetic design, can fit into any home decor with ease.

Equipped with a range of features to make heating the home much easier, along with H-shaped vertical support to provide high-volume easy installations.



ErP Lot 20



Class II and IP24 Protection



Click & Go



Open/Closed Window Detection



LCD Digital Control Panel



High Precision Electric Thermostat



FIND
OUT
MORE



AGILIA IO

PANEL HEATER

Designed with a simplistic and modern symmetrical style, the Agilia IO can work perfectly with any home decor design with complete ease.

Engineered to be slim and compact, the Agilia IO electric panel heater combines comfort, energy, and space-saving benefits into one complete elegant radiator.



ErP Lot 20



Cozytouch
Compatible



Click & Go



Double
Heating
Elements



45% Energy
Savings*



Open/Closed
Window
Detection



FIND
OUT
MORE

* When compared to an analogue electric radiator



Calypso

FEATURES

-  A+ ErP rating
-  Over 300% Efficient
-  Low Noise Emission: 49db
-  Duplex Stainless Steel Tank
-  Cozytouch Compatible
-  Integrated Air Source Heat Pump



Atlantic Explorer

FEATURES



A+ ErP rating



Low noise emission: 53db



Diamond quality enamelled glass tank



Integrated air source heat pump (air to water)



Cozytouch compatible



Compact design

Energy efficiency.

WHAT IS ERP?

- ErP is a regulation put in place by the European Union to increase the visibility of the efficiency and performance of heating and hot water products, allowing you to be aware of the impact of your purchases.
- Efficiency isn't something you need to worry about when choosing Ideal Heating, as all of our boilers achieve band A levels of efficiency, helping you to reduce your energy bills and carbon footprint.

All of our boilers achieve band A ErP rating of at least

92%



Quality service year round.

Delivering industry leading customer support is our promise to you, which is why our Ireland based contact centre is open 5 days a week.



Ireland based call centre



5 days a week



Year round customer support



Technically trained team



At Ideal Heating we understand the importance of quality customer care and post sales support, which is why we have invested £4 million in our services to support you.

If your query cannot be resolved over the phone, we have a team of service engineers all over Ireland to ensure we provide a rapid response typically the same or next day.



To ensure we are always achieving highest standards of customer service, all our customers are offered the opportunity to provide feedback on their interactions with us.



We don't just offer industry-leading warranties, we offer industry-leading aftersales service for the life of our products.

You can be assured after having one of our boilers fitted, you will continue to receive the highest standards of customer service even after the warranty expires.

SUPPORT TELEPHONE:

01-9617700



OPENING TIMES

MONDAY - THURSDAY

8:00 - 17:00

CLOSED FOR LUNCH BETWEEN

13:00 - 14:00

FRIDAY

8:00 - 16:00

CLOSED FOR LUNCH BETWEEN

13:00 - 14:00

ideal
HEATING

YOUR IDEAL INSTALLER IS:

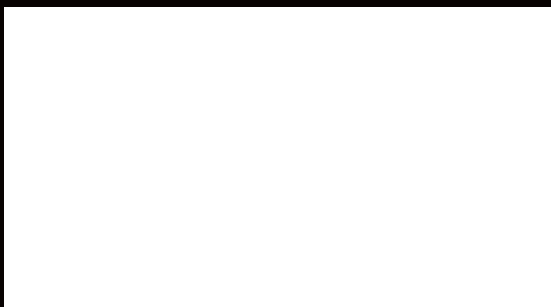

info@idealenergy.ie | 01-9617700
Ideal Energy Distribution, Ascot House, Kinsealy Lane,
Malahide, Co. Dublin, K36 HH42

idealenergy.ie

DISTRIBUTED BY
IDEAL
ENERGY

The information in this brochure was correct at the time of going to print. Ideal Heating reserve the right to make any modifications to product specifications or any other details, without prior notification. For further clarification, please enquire in writing to the head office address above.