



USER GUIDE

**LOGIC COMBI²
C24 IE C30 IE C35 IE**

When replacing any part on this appliance, use only spare parts that you can be assured conform to the safety and performance specification that we require. Do not use reconditioned or copy parts that have not been clearly authorised by Ideal Heating.

For the very latest copy of literature for specification and maintenance practices visit our website idealheating.com where you can download the relevant information in PDF format.

May 2023

UIN 236463 A02



WEEE DIRECTIVE 2012/19/EU
Waste Electrical and Electronic Equipment Directive

- At the end of the product life, dispose of the packaging and product in a corresponding recycle centre.
- Do not dispose of the unit with the usual domestic refuse.
- Do not burn the product.
- Remove the batteries.
- Dispose of the batteries according to the local statutory requirements and not with the usual domestic refuse.



Ideal Heating is a member of the Benchmark scheme and fully supports the aims of the programme. Benchmark has been introduced to improve the standards of installation and commissioning of central heating systems in the UK and to encourage the regular servicing of all central heating systems to ensure safety and efficiency.



THE BENCHMARK SERVICE INTERVAL RECORD MUST BE COMPLETED AFTER EACH SERVICE

CONTENTS

1.1 Introduction	3	1.6 General Information	7
1.2 Boiler Operation	4-5	1.7 Troubleshooting	8
1.3 System Water Pressure	6	1.8 Normal Operation Display Codes	8
1.4 Points for the Boiler User	6	1.9 Fault Codes	9
1.5 Condensate Drain (Unblocking)	7		

1.1 INTRODUCTION

The Logic Combi² C IE is a combination boiler providing both central heating and instantaneous domestic hot water. Featuring full sequence automatic ignition and fan assisted combustion.

Due to the high efficiency of the boiler, condensate is produced from the flue gases and this is drained to a suitable disposal point through a plastic waste pipe at the base of the boiler. A condensate 'plume' will also be visible at the flue terminal.

Safety

CURRENT GAS SAFETY (INSTALLATION & USE) REGULATIONS OR RULES IN FORCE.

The installation must be carried out by a Registered Gas Installer (RGI) and installed in accordance with the current edition of I.S. 813 "Domestic Gas Installations", the current Building Regulations and reference should be made to the current ETCI rules for electrical installation.

It is essential that the instructions in this booklet are strictly followed, for safe and economical operation of the boiler.

ELECTRICITY SUPPLY

This appliance must be earthed.

Supply: 230 V ~ 50 Hz. The fusing should be 3A.

! IMPORTANT NOTES

- This appliance must not be operated without the casing correctly fitted and forming an adequate seal.
- If the boiler is installed in a compartment then the compartment **MUST NOT** be used for storage purposes.
- If it is known or suspected that a fault exists on the boiler then it **MUST NOT BE USED** until the fault has been corrected by a Registered Gas Installer (RGI) .
- Under **NO** circumstances should any of the sealed components on this appliance be used incorrectly or tampered with.
- **This appliance can be used by children 8 years and above. Also persons with reduced physical, sensory or mental capabilities, or lack of experience and knowledge, provided they have been given supervision or instruction concerning use of the appliance in a safe way and understand the hazards involved. Children shall not play with the appliance. Cleaning and user maintenance shall not be made by children without supervision.**

1.2 BOILER OPERATION

Legend

- A. Domestic Hot Water Temperature Knob
- B. Central Heating Temperature Knob
- C. Mode Button
- D. Boiler Status Display
- E. Burner On indicator
- F. Restart Button
- G. Pressure Gauge

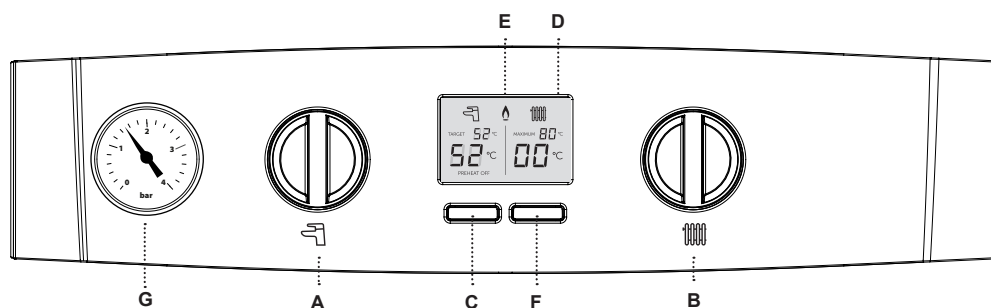

To START the boiler

If a programmer is fitted refer to separate instructions for the programmer before continuing.

Start the boiler as follows:

1. Ensure that all hot water taps are turned off.
2. Check that the electricity supply to boiler is on.
3. Press the mode button until a cross is not shown through the radiator symbol.
4. Turn the Domestic Hot water temperature knob (A) clockwise until a 65°C target temperature is shown. Turn the Central Heating temperature knob (B) clockwise until an 80°C target temperature is shown.

The boiler will commence ignition sequence, supplying heat to the central heating, if required.

Note. In normal operation the boiler status display (D) will show codes:

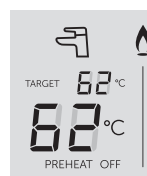

Boiler is active for Domestic Hot Water



Boiler is heating up the Plate Heat Exchanger



Boiler is active for boiler frost protection: operates if the ambient temperature is below 5°C until it reaches 19°C.



Boiler is in Lockout for a specific error. Display will show a number after the "L" to indicate which error is detected



Boiler has a fault for a specific error. Display will show a number after the "F" to indicate which error is detected.

During normal operation the burner on indicator 'E' will remain illuminated when the burner is lit.

Note: If the boiler fails to light after five attempts the fault code L2 will be displayed (refer to Fault Code page).

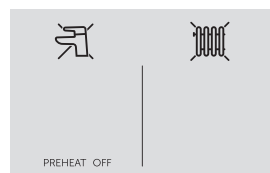

Boiler Off Mode

Press the Mode button once to enable DHW or twice to enable CH.



CH Off

Press the Mode button until the cross disappears to enable CH.

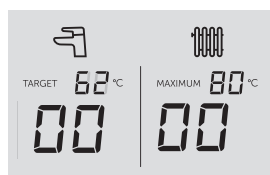

Winter Mode, no heat demand

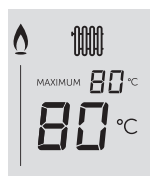

Boiler is active for Central Heating

OPERATION MODES

WINTER CONDITIONS - (CENTRAL HEATING AND DOMESTIC HOT WATER REQUIRED)

Press the mode button until there is not a cross through the radiator symbol.

The boiler will fire and supply heat to the radiators but will give priority to domestic hot water on demand.

The domestic hot water preheat will operate if the preheat has been enabled. If Preheat On is shown at the bottom left of the display then preheat is enabled, if Preheat Off is shown then it is disabled.

Summer Conditions - (Domestic Hot Water only required)

Press the mode button until a cross is shown through the radiator, but a cross is not shown through the tap.

Set the central heating demand on the external controls to OFF.

The domestic hot water preheat will operate if the preheat has been enabled. If Preheat On is shown at the bottom left of the display then preheat is enabled, if Preheat Off is shown then it is disabled.

BOILER OFF

Press the mode button until crosses are shown through both the tap and radiator symbols.

PREHEAT - DOMESTIC HOT WATER

The domestic hot water heat exchanger within the boiler can be preheated to provide faster delivery of hot water at the tap.

The boiler is factory set with the preheat turned off to give standard hot water delivery and reduce gas usage.

If required, the preheat can be switched on during installation for faster domestic hot water delivery. With preheat turned on, 'Timed' is shown on the display as this boiler has a timed intelligent preheat function which learns the usage pattern for domestic hot water over 24 hours. It then fires the boiler periodically for a few seconds to maintain the temperature of the domestic hot water heat in the boiler, as required to meet the predicted hot water draw-off. This improves the speed of response for DHW whilst minimising the use of gas.

CONTROL OF WATER TEMPERATURE DOMESTIC HOT WATER

The domestic hot water temperature is limited by the boiler controls to a maximum temperature of 65°C, adjustable via the domestic hot water temperature knob (A).

Approximate temperatures for domestic hot water:

Knob Setting	Hot Water Temperature (approx.)
Minimum	40°C
Maximum	65°C

Due to system variations and seasonal temperature fluctuations, domestic hot water flow rates/temperature rise will vary, requiring adjustment at the tap: the lower the flow rate the higher the temperature, and vice versa.

CENTRAL HEATING

The boiler controls the central heating radiator temperature to a maximum of 80°C, adjustable via the central heating temperature knob (B).

Approximate temperatures for central heating:

Knob Setting	Central Heating Radiator Temperature (approx.)
Minimum	30°C
Maximum	80°C

Set to 72°C or less for high efficiency operation.

EFFICIENT HEATING SYSTEM OPERATION

The boiler is a high efficiency, condensing appliance which will automatically adjust its output to match the demand for heat. Therefore gas consumption is reduced as the heat demand is reduced.

The boiler condenses water from the flue gases when operating most efficiently. To operate your boiler efficiently (using less gas) turn the central heating temperature knob (B) lower. In winter periods it may be necessary to turn the knob towards a higher temperature position to meet heating requirements. This will depend on the house and radiators used.

Reducing the room thermostat setting by 1°C can reduce gas consumption by up to 10%.

WEATHER COMPENSATION

When the Weather Compensation option is fitted to the system then the central heating temperature knob (B) becomes a method of controlling room temperature. Turn the knob clockwise to increase room temperature and anti-clockwise to decrease room temperature. Once the desired setting has been achieved, leave the knob in this position and the system will automatically achieve the desired room temperature for all outside weather conditions.

BOILER FROST PROTECTION

The boiler is fitted with frost protection that operates in all modes, provided the power supply to the boiler is always turned on. If the water in the boiler falls below 5°C, the frost protection will activate and run the boiler to avoid freezing. The process does not guarantee that all other parts of the system will be protected.

If a system frost thermostat has been installed, the boiler must be set in winter mode, "(there should not be a cross through the radiator symbol)", for the system frost protection to run.

If no system frost protection is provided and frost is likely during a short absence from home it is recommended to leave the system heating controls or built in programmer (if fitted) switched on and run at a reduced temperature setting.

For longer periods, the entire system should be drained.

BOILER RESTART

To restart the boiler, when directed in the listed fault codes (see section 1.9) press the restart button (F). The boiler will repeat its ignition sequence. If the boiler still fails to start consult a Registered Gas Installer (RGII).

MAINS POWER OFF

To remove all power to the boiler the mains power switch must be turned off.

1.3 SYSTEM WATER PRESSURE

The system pressure gauge indicates the central heating system pressure. If the pressure is seen to fall below the original installation pressure over a period of time and continue to fall then a water leak may be indicated. In this event re-pressurise the system. If repressurisation of the system is not possible, or if the system pressure continues to drop, the a Registered Gas Installer (RGI) should be called.

THE BOILER WILL NOT OPERATE IF THE PRESSURE HAS REDUCED TO LESS THAN 0.3 BAR UNDER THIS CONDITION.

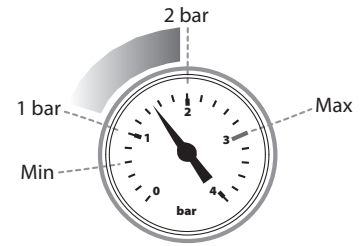

To Top up the system :-

1. Ensure both (A) & (B) handles (blue & green) are in closed position (as shown below)
2. Remove the plug and cap and retain.
3. Connect the filling loop to the Domestic Hot Water (DHW) inlet and tighten. Also ensure that the other end of filling loop is hand tight.
4. Turn the Domestic Hot Water (DHW) Inlet (A) blue handle to the horizontal position.
5. Ensuring no leaks are seen, gradually turn the filling loop handle (green) (B) to the horizontal position.

6. Wait for the pressure gauge to reach 1 to 1.5 bar.
7. Once pressure is reached turn valves (A) & (B) back to the closed position.
8. Disconnect the filling loop, replace cap and plug.

Note. There can be some water spillage at this point.

SCAN
for video



Filling Positions shown

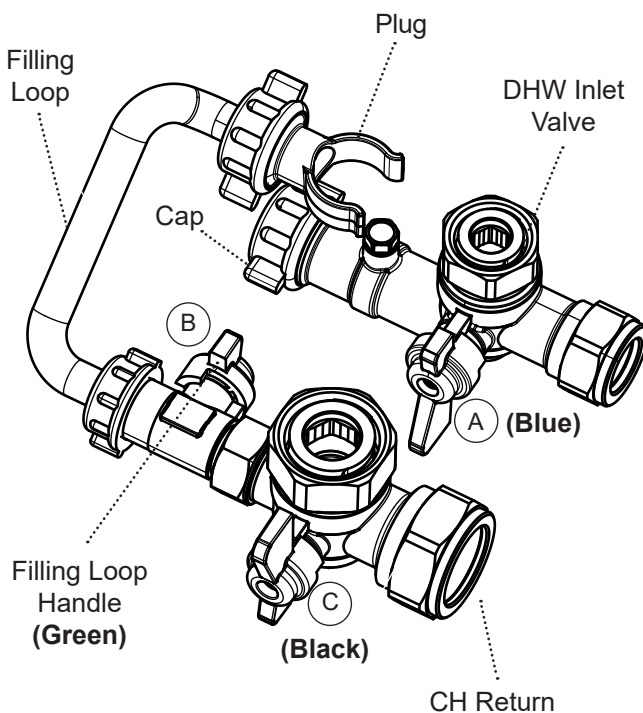

Top Up Positions shown

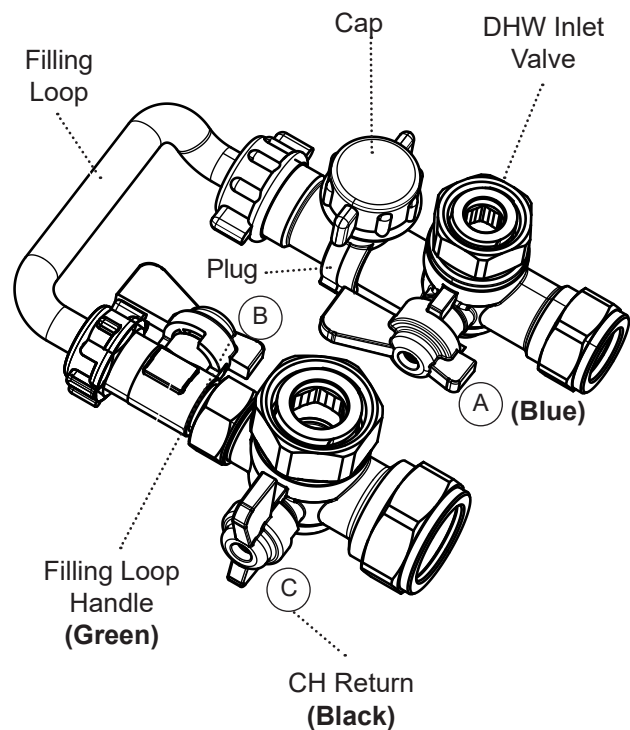

1.4 POINTS FOR THE BOILER USER

In line with our current warranty policy we would ask that you check through the following guide to identify any problems external to the boiler prior to requesting a service engineers visit. Should the problem be found to be other than with the appliance we reserve the right to levy a charge for the visit, or for any pre-arranged visit where access is not gained by the engineer.

FOR ANY QUERIES PLEASE RING THE IDEAL CONSUMER HELPLINE : 00353 (0)1 961 7700

BOILER RESTART PROCEDURE - To restart boiler press the restart button

1.5 UNBLOCKING THE CONDENSATE DRAIN

This appliance is fitted with a siphonic condensate trap system that reduces the risk of the appliance condensate from freezing. However should the condensate pipe to this appliance freeze, please follow these instructions:

- a. If you do not feel competent to carry out the defrosting instructions below please call your local Gas Safe Registered installer for assistance.
- b. If you do feel competent to carry out the following instructions please do so with care when handling hot utensils. **DO NOT** attempt to thaw pipework above ground level.

If this appliance develops a blockage in its condensate pipe, its condensate will build up to a point where it will make a gurgling noise prior to locking out, showing a "LO2" fault code.

To unblock a frozen condensate pipe;

1. Follow the routing of the plastic pipe from its exit point on the appliance, through its route to its termination point.
Locate the frozen blockage. It is likely that the pipe is frozen at the most exposed point external to the building or where there is some obstruction to flow. This could be at the open end of the pipe, at a bend or elbow, or where there is a dip in the pipe in which condensate can collect. The location of the blockage should be identified as closely as possible before taking further action.

2. Apply a hot water bottle, microwaveable heat pack or a warm damp cloth to the frozen blockage area. Several applications may have to be made before it fully defrosts. Warm water can also be poured onto the pipe from a watering can or similar. **DO NOT** use boiling water.
3. Caution when using warm water as this may freeze and cause other localised hazards.
4. Once the blockage is removed and the condensate can flow freely, restart the appliance. (Refer to "To Start the boiler")
5. If the appliance fails to ignite, call your Registered Gas Installer (RGII) .

Preventative solutions

During cold weather, set the central heating temperature knob (B) to maximum (must return to original setting once cold spell is over).

Place the heating on continuous and turn the room thermostat down to 15°C overnight or when unoccupied. (Return to normal after cold spell).

SCAN
for video



1.6 GENERAL INFORMATION

BOILER PUMP

The boiler pump will operate briefly as a self-check once every 24 hours, regardless of system demand.

MINIMUM CLEARANCES

Clearance of 165 mm above, 100 mm below, 2.5 mm at the sides and 450 mm at the front of the boiler casing must be allowed for servicing.

Bottom Clearance

Bottom clearance after installation can be reduced to 5 mm.

This must be obtained with an easily removable panel, to enable the system pressure gauge to be visible and to provide the 100 mm clearance required for servicing.

EXPANSION

Note. If a water meter is fitted into the incoming water mains there may be a requirement for a domestic hot water expansion vessel Kit. Contact a Registered Gas Installer (RGII) .

ESCAPE OF GAS

Should a gas leak or fault be suspected contact the National Gas Emergency Service **1800 20 50 50** without delay.

Ensure that:

- **All naked flames are extinguished.**
- **Do not operate electrical switches.**
- **Open all windows and doors.**

CLEANING

For normal cleaning simply dust with a dry cloth. To remove stubborn marks and stains, wipe with a damp cloth and finish off with a dry cloth. **DO NOT use abrasive cleaning materials.**

MAINTENANCE

The frequency of servicing will depend upon the installation condition and usage but should be carried out at least annually by a Registered Gas Installer (RGII) .

1.7 TROUBLESHOOTING

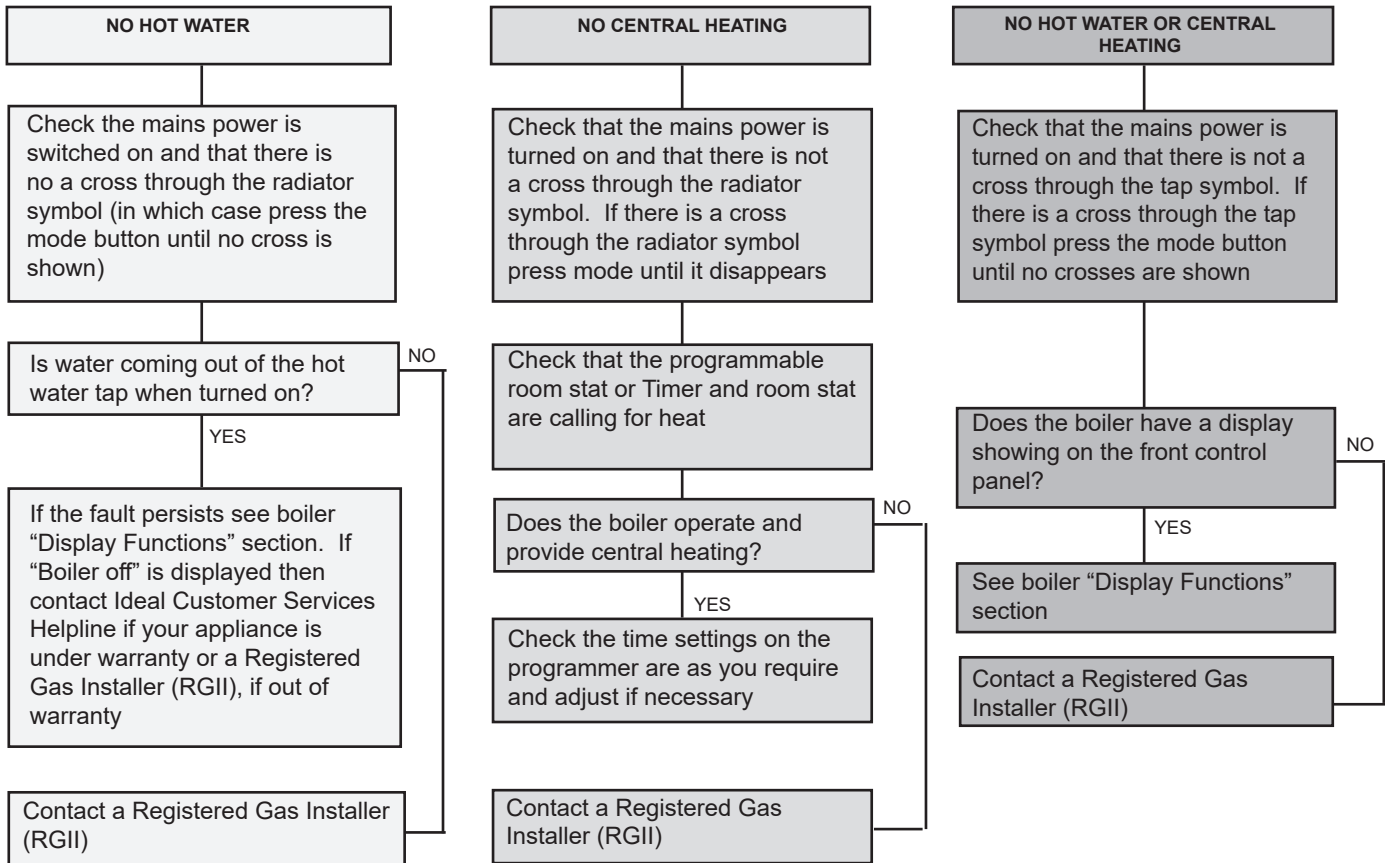

1.8 NORMAL OPERATION DISPLAY CODES

The user control has one display to inform the user about the status of the boiler. The display shows the status of the flame. If no flame is detected then flame symbol will not be visible. When the flame is detected the flame symbol will be visible permanently.

Below is a list with display function.

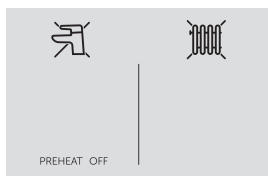

Boiler Off Mode

Press the Mode button once to enable DHW or twice to enable CH.

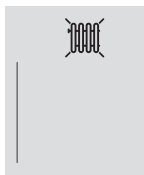

CH Off

Press the Mode button until the cross disappears to enable CH.

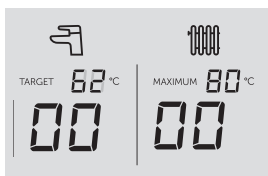

Winter Mode, no heat demand

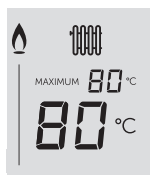

Boiler is active for Central Heating

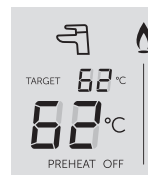

Boiler is active for Domestic Hot Water



Boiler is heating up the Plate Heat Exchanger

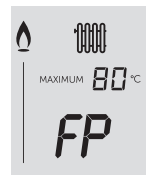

Boiler is active for boiler frost protection: operates if the ambient temperature is below 5°C until it reaches 19°C.



Boiler is in Lockout for a specific error. Display will show a number after the "L" to indicate which error is detected

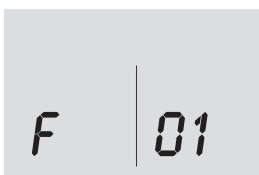

Boiler has a fault for a specific error. Display will show a number after the "F" to indicate which error is detected.

1.9 FAULT CODES

DISPLAY CODE ON BOILER	DESCRIPTION	ACTION
<u>F 01</u>	Low Water Pressure	Check system water pressure is between 1 & 1.5bar on the system pressure gauge. To re-pressurise the system see Section 3. If the boiler still fails to operate then please contact Ideal (if under warranty) or alternatively a Registered Gas Installer (RGII) if outside of the warranty period.
<u>F 02</u>	Flame Loss	1. Check other gas appliances in the house are working to confirm a supply is present in the property. 2. If other appliances do not work or there are no other appliances, check the gas supply is on at the meter and/or pre payment meter has credit. If the boiler fails to operate then please contact Ideal (if under warranty) or alternatively a Registered Gas Installer (RGII) if outside of the warranty period.
<u>F03</u>	Fan Fault	Restart the appliance - if the boiler fails to operate then please contact Ideal (if under warranty) or alternatively a Registered Gas Installer (RGII) if outside of the warranty period.
<u>F 04</u> <u>L 04</u>	Flow Thermistor	Restart the appliance - if the boiler fails to operate then please contact Ideal (if under warranty) or alternatively a Registered Gas Installer (RGII) if outside of the warranty period.
<u>F 05</u> <u>L 05</u>	Return Thermistor	Restart the appliance - if the boiler fails to operate then please contact Ideal (if under warranty) or alternatively a Registered Gas Installer (RGII) if outside of the warranty period.
<u>F 06</u>	Outside Sensor Failure	Restart the appliance - if the boiler fails to operate then please contact Ideal (if under warranty) or alternatively a Registered Gas Installer (RGII) if outside of the warranty period.
<u>F 07</u>	Low Mains Voltage	Contact a qualified electrician or your electricity provider.
<u>F09</u> <u>L 09</u>	Unconfigured PCB	Unconfigured/faulty PCB or gas valve short circuit. Please contact Ideal (if under warranty) or alternatively a Registered Gas Installer (RGII) if outside of the warranty period.
<u>L 01</u>	Flow Temperature Overheat or No Water Flow	Check system water pressure is between 1 & 1.5 bar on the system pressure gauge. To re-pressurise the system see Section 3. If the boiler fails to operate then please contact Ideal (if under warranty) or alternatively a Registered Gas Installer (RGII) if outside of the warranty period.
<u>L 02</u>	Ignition Lockout	1. Check condensate Pipe for blockages 2. Check other gas appliances in the house are working to confirm a supply is present in the property. 3. If other appliances do not work or there are no other appliances, check the gas supply is on at the meter and/or pre payment meter has credit. If the boiler fails to operate then please contact Ideal (if under warranty) or alternatively a Registered Gas Installer (RGII) if outside of the warranty period.
<u>L06</u>	False Flame Lockout	Restart the appliance - if the boiler fails to operate then please contact Ideal (if under warranty) or alternatively a Registered Gas Installer (RGII) if outside of the warranty period.
<u>LOC</u>	5 Boiler Resets in 15 minutes	1. Turn electrical supply to boiler off and on. 2. If the boiler fails to operate please contact Ideal (if under warranty) or alternatively a Registered Gas Installer (RGII) if outside of the warranty period.
<u>LOd</u>	Blocked Flue/Condensate	1. Check condensate Pipe for blockages 2. Check other gas appliances in the house are working to confirm a supply is present in the property. 3. If other appliances do not work or there are no other appliances, check the gas supply is on at the meter and/or pre payment meter has credit. If the boiler fails to operate then please contact Ideal (if under warranty) or alternatively a Registered Gas Installer (RGII) if outside of the warranty period.
<u>FOU</u>	Flow/Return Differential > 50°C	If the boiler fails to operate then please contact Ideal (if under warranty) or alternatively a Registered Gas Installer (RGII) if outside of the warranty period.
<u>d U</u>	Diverter Valve in mid-position for service	Rotate all knobs fully clockwise, turn boiler power off and on then press restart.
<u>FOC</u>	DHW Thermistor Fault	If the boiler fails to operate please contact Ideal (if under warranty) or alternatively a Gas Safe Registered Engineer if outside of the warranty period.

Refer to Section
1.5



Technical Training

Our Expert Academy offer a range of training options designed and delivered by our experts in heating.
For details please visit: expert-academy.co.uk

Ideal Boilers Ltd., pursues a policy of continuing improvement in the design and performance of its products.
The right is therefore reserved to vary specification without notice.

Ideal is a trademark of Ideal Boilers.

Registered Office

Ideal Boilers Ltd., National Avenue, Hull, East Yorkshire, HU5 4JB

Tel 01482 492251 Fax 01482 448858

Registration No. London 322 137

EU Authorised Representative:

Atlantic SFDT

44 Boulevard des Etats-Unis, 85 000 La Roche-Sur-Yon, France

+33 (0)2 51 44 34 34

Ideal Technical & Consumer Helpline: 00353 (0)1 961 7700

Ideal Parts: 00353 (0)1 961 7700

idealboilers.ie

ideal
HEATING